

Series PRA PHA

Absolute hollow shaft encoder,
high settlement; self-aligning system panted

PRA = Absolute parallel

PHA = Absolute parallel
with Hall effect



Mechanics Data

Cover:	SMC fiber glass + ABS
Body:	Aluminium
Solid shaft:	Stainless steel
Bearings:	2, ballraces
Weight:	Approx.150gr.
Protection:	IP65
Rpm:	6000 Max
Torque:	3Ncm
Inertia:	40gcm ²
Shaft loading:	Axial 30N - Radial 30N
Recovery max value:	Angular 1,5° -0,5mm axial and radial

Dimensions in mm

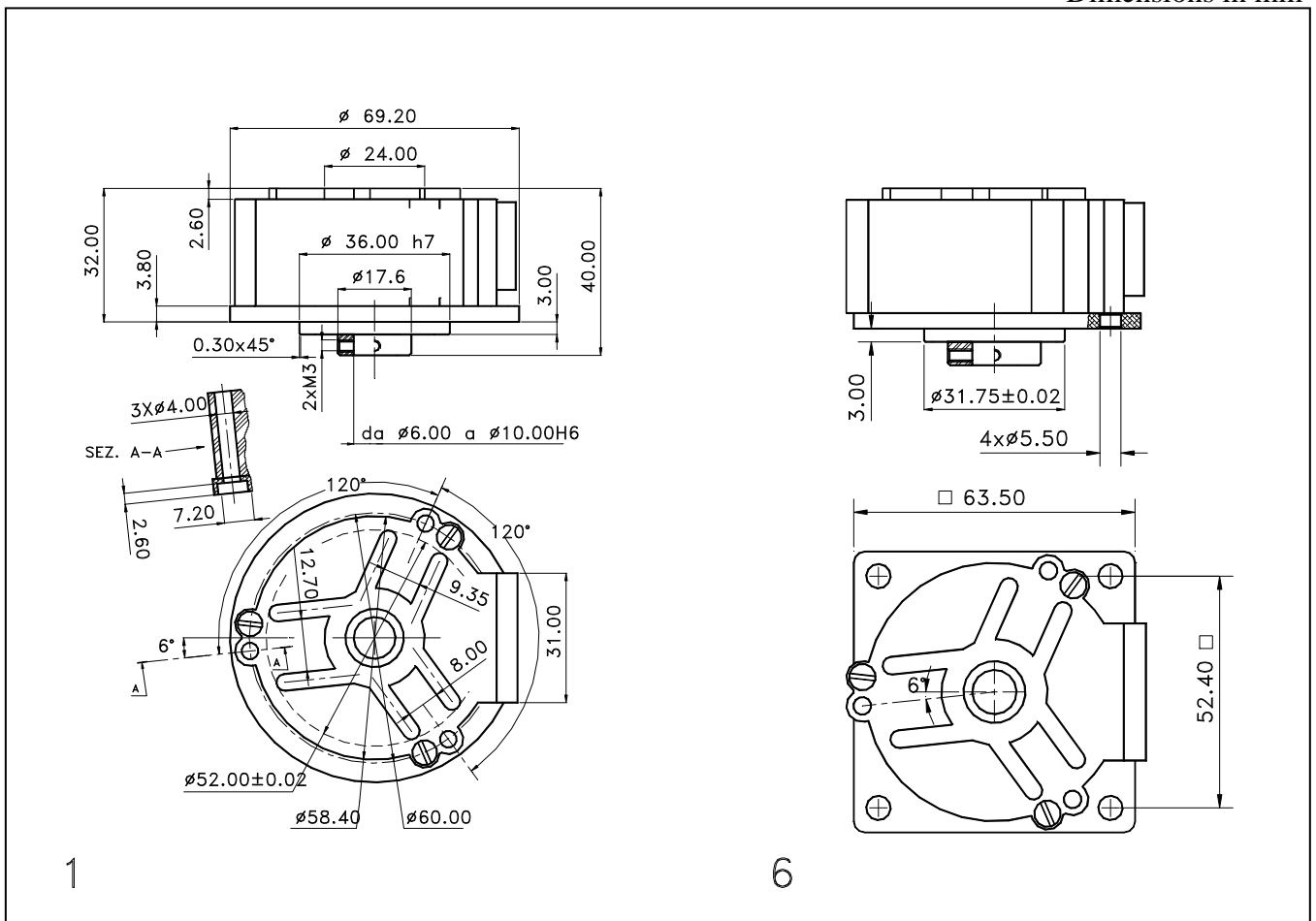

**Series
PRA-PHA**

Electronics Data

Power supply: from 5 to 24V depends on the electronics circuit
 Current consumption: 20mA
 Max power: 2Watt
 Permissible load: 20mA
 Frequency: 100KHz (max 6000 rpm)
 Protections: Against short circuit, reversal polarity
 Operating Temp.: 0/+60°C

Ordering code

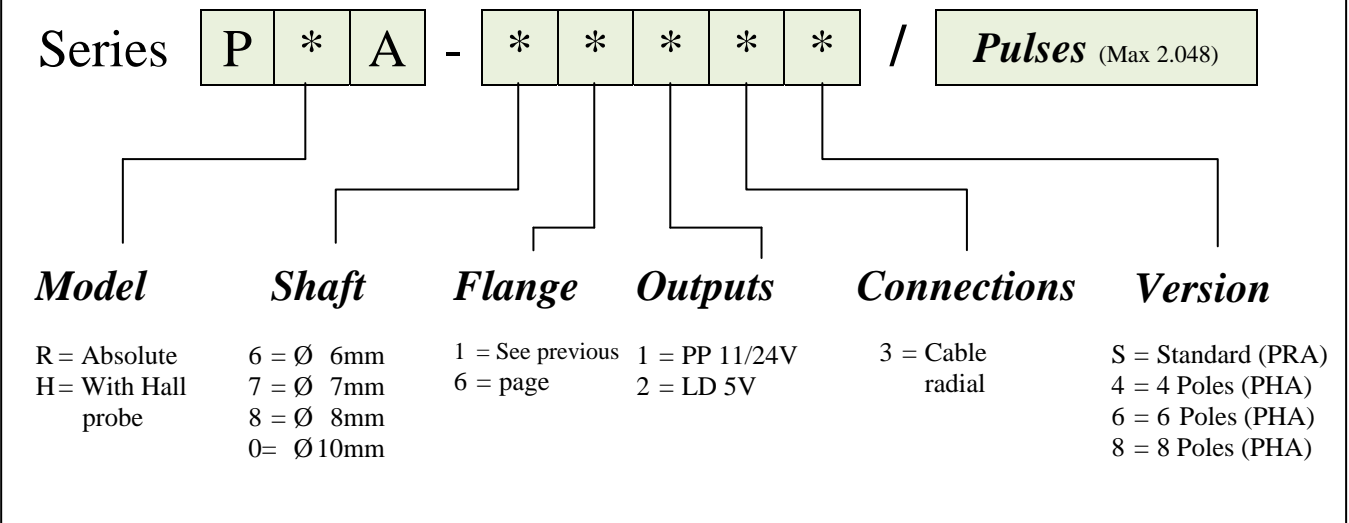

Connections

	Absolute encoder: output bit															Hall probe							
	- Volt	+ Volt	U/D	G/B	MSB → LSB											H0	H1	H2					
	1	2	3	4	5	6	7	8	9	10	11	12	13	14	15	16	17	18					
Cable	B L A C K	B L U E	Y E L L O W	W H I T E	Y E L L O W	G R E Y	Y E L L O W	G R E Y	V I O L E T	P I N K	O R A N G E	T R A N S P A R	R E D	W H I T E	B L U E	W H I T E	G R E Y	W H I T E	B L U E	W H I T E	V I O L E T	W H I T E	O R A N G E

Legend connections:

MSB = Most Significant Bit

LSB = Low Significant Bit

U/D = Up / Down direction signals (clockwise or anticlockwise)

G/B = Gray or Binary

H0..2 = Hall probe (outputs signals)

N.B. Encoder inputs are internally connected to logical "1"

The standard configuration is as follows: outputs code: Gray; clockwise increment (UP)

Connecting input to logical "0", the configuration changes, output code: Binary, anticlockwise increment (UP)