

Series MS

Absolute single turn shaft encoder
high resolution (ø65mm)

Mechanics Data

Cover:	Lacquered aluminium
Body:	Aluminium
Solid shaft:	Stainless steel
Bearings:	2, ballraces
Weight:	Approx.300gr.
Protection:	IP65
Rpm:	6000 Max
Torque:	5Ncm
Inertia:	100gcm ²
Shaft loading:	Axial 100N - Radial 100N



Dimensions in mm.

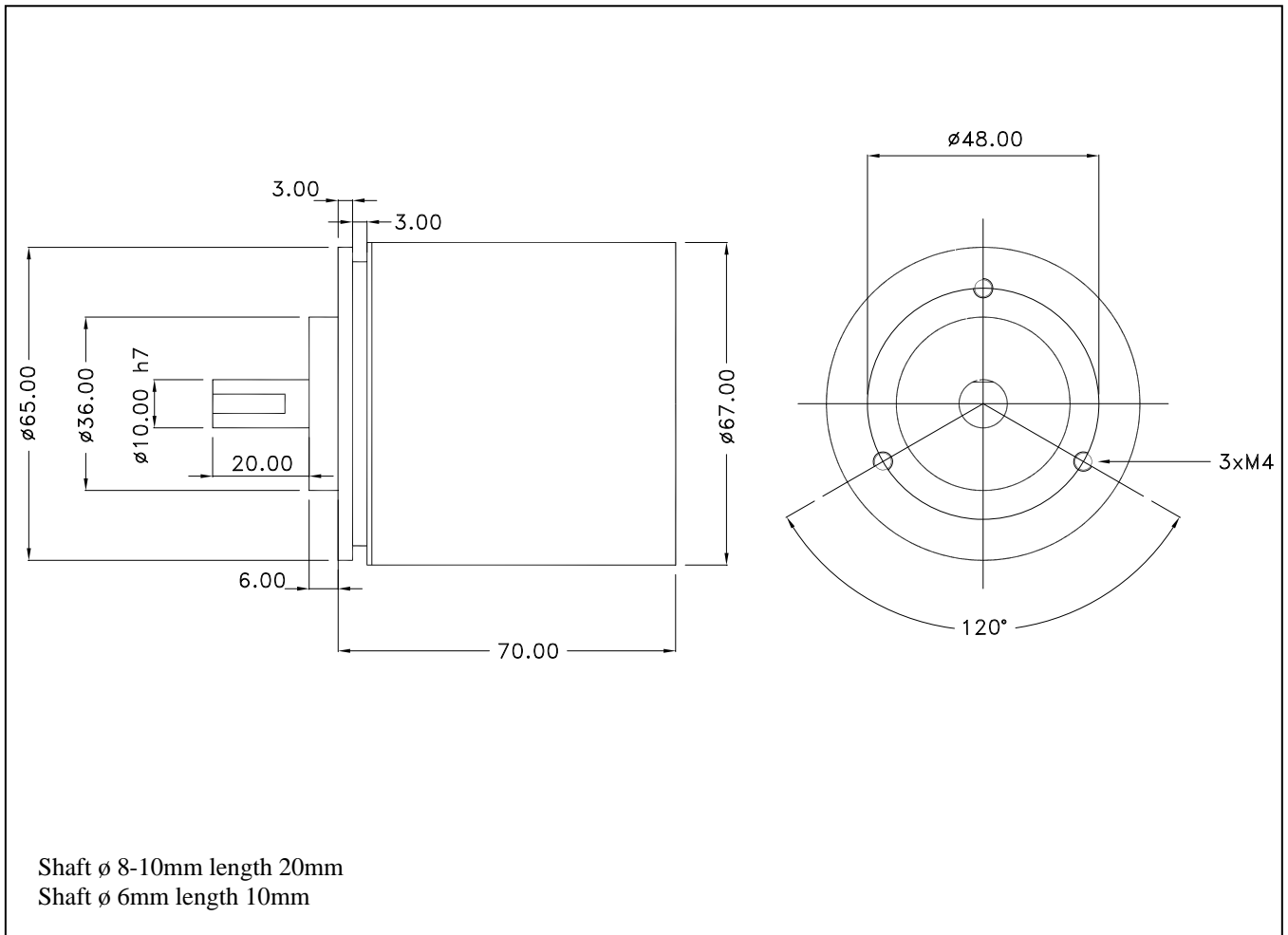

Series MS

Electronics Data

Power supply: from 5 to 24V depends on the electronics circuit
 Current consumption: 40/80mA depends on the electronics circuit
 Permissible load: 40mA
 Frequency: 50KHz (standard in LSB)
 Protections: Against short circuit, reversal polarity
 Operating Temp.: -20/+60°C

Ordering code

Series **M S** - *** 3 * * *** / **Pulses** (Max 8.192)
See page pulses

Shaft	Outputs	Options	Connections
3 = Ø 6mm 6 = Ø 8mm 1 = Ø 10mm	1 = GRAY NPN 11/24V 2 = GRAY Push-Pull 11/24V 3 = GRAY TTL 5V 4 = BIN. NPN 11/24V 5 = BIN. Push-Pull 11/24V 6 = BIN. TTL 5V 7 = BCD NPN 11/24V 8 = BCD Push-Pull 11/24V 9 = BCD TTL 5V	A = None B = Open Coll. P = Parity parity D = Parity Odd E = GRAY Excess S = Strobe Z = Zero settings (only for output 2 e 5)	3 = Cable Radial 9 = Cable Axial R = 9413 Radial N = 9413 Axial 5 = 9416/9426 Rad 2 = 9416/9426 Ass (contact Hohner)

Connections

	0 Volt	+ Volt	0 2	1 2	2 2	3 2	4 2	5 2	6 2	7 2	8 2	9 2	10 2	11 2	M	DIR <->	
Connector 9416 12p	P1	P2	P3	P4	P5	P6	P7	P8	P9	P10	P11					P12	
Conn 9416 16p - 9413	P1	P2	P3	P4	P5	P6	P7	P8	P9	P10	P11	P12	P13	P14	P15	P16	
Cable	B L A C K	B L U E	B R O W N	B E I G E	G R E E N	Y E L L O W	P I N K	V I O L E T	O R A N G E	T R A N S P A R E	W H I T E	R E D	W H I T E	G R E E N	V I O L E T	Y E L L O W	Y E L L O W

Legend connections:
 M = optional outputs:
 DIR <-> = is the signal direction: clockwise or anticlockwise
 Clockwise standard
 Anticlockwise connect DIR <-> to **0Volt**.