

Series TS

Absolute single turn shaft encoder
high resolution ($\varnothing 90\text{mm}$)



Mechanics Data

Cover:	Lacquered aluminium
Body:	Aluminium
Solid shaft:	Stainless steel
Bearings:	2, ballraces
Weight:	Approx.600gr.
Protection:	IP65
Rpm:	6000 Max
Torque:	5Ncm
Inertia:	100gcm ²
Shaft loading:	Axial 100N - Radial 100N (the value decrease when the number of pulses increase)

Dimensions in mm.

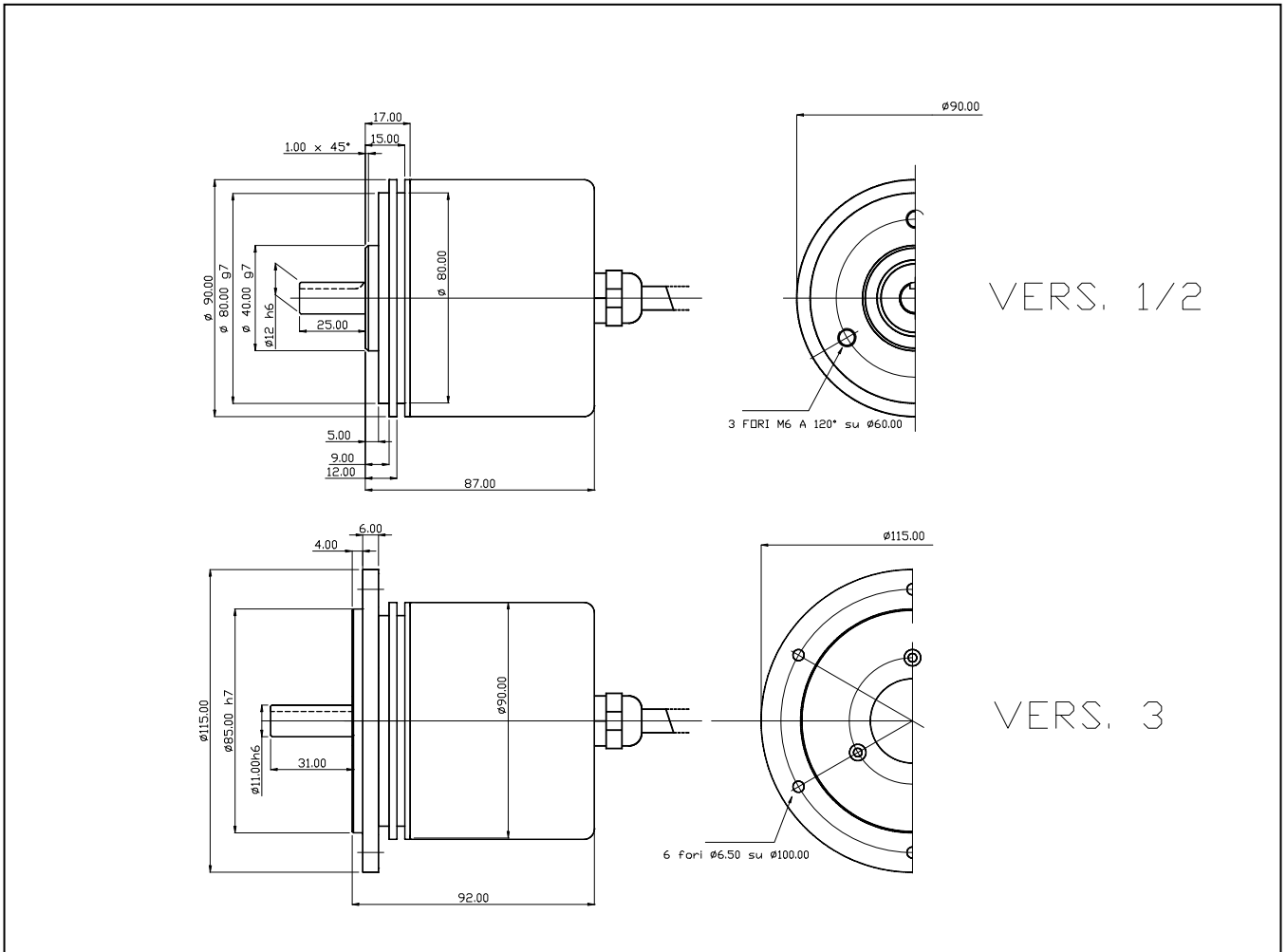

Series TS

Electronics Data

Power supply: from 5 to 24V depends on the electronics circuit
 Current consumption: 40/80mA depends on the electronics circuit
 Permissible load: 40mA
 Frequency: 50KHz (standard in LSB)
 Protections: Against short circuit, reversal polarity
 Operating Temp.: -20/+60°C

Ordering code

Series **T S** - *** 3 * * *** / **Pulses** (Max 8.192)
See page 4

Version	Code/Outputs	Connections	Connector	Options
1 = Shaft Ø10mm Flange Ø 90mm	1 = Gray/Binary NPN 11/24V 2 = Gray/Binary PP 11/24V	1 = Cable 2 = 9426	A = Axial R = Radial	0 = None 1 = Latch
2 = Shaft Ø12mm Flange Ø 90mm	3 = Gray/Binary TTL 5V 4 = Gray/Binary OC 11/24V	3 = 9413 4 = 9428		2 = Reset 3 = Preset
3 = Shaft Ø11mm Flange Ø115mm	5 = BCD NPN 11/24V 6 = BCD PP 11/24V 7 = BCD TTL 5V 8 = BCD OC 11/24V	5 = 9432		4 = Tristate 5 = Static Strobe 6 = Dynamic Strobe 7 = Parity odd 8 = Parity even 9 = Gray Excess Z = zero settings

Connections

Code: Gray/Binary	0	+	0	1	2	3	4	5	6	7	8	9	10	11	G/B	DIR	
	Volt	Volt	2	2	2	2	2	2	2	2	2	2	2	2		<->	
Code: BCD			0				1				2						
	0	+	10				10				10				M	DIR	
	Volt	Volt	1	2	4	8	1	2	4	8	1	2	4	8		<->	
Connector: 9413 - 9426 - 9428 - 9432	P1	P2	P3	P4	P5	P6	P7	P8	P9	P10	P11	P12	P13	P14	P15	P16	
Cable	B L A C K	B L U E	B R O W N	B E I G E	G R E E N	Y E L L O W	P I N K	V I O L E T	O R A N G E	T R A N S P A R	W H I T E	W H I T E	G R E E N	V I O L E T	Y E L L O W	Y E L L O W	Y E L L O W

Legend connections:
 M = optional outputs:
 DIR <-> = is the signal direction: clockwise or anticlockwise
 Clockwise standard
 Anticlockwise connect DIR <-> to **0Volt**
 Gray code standard. For Binary code connect pin G/B to **0Volt**