

Series BS

Incremental semi-hollow shaft encoder

Mechanics Data

Cover:	Lacquered aluminium
Body:	Aluminium
Solid shaft:	Stainless steel
Bearings:	2, ballraces
Weight:	Approx.300gr.
Protection:	IP54 (IP65 on request, Max 3000RPM)
Rpm:	6000 Max
Torque:	5Ncm
Inertia:	100gcm ²
Shaft loading:	Axial 50N - Radial 50N (the value decrease when the number of pulses increase)



Dimensions in mm.

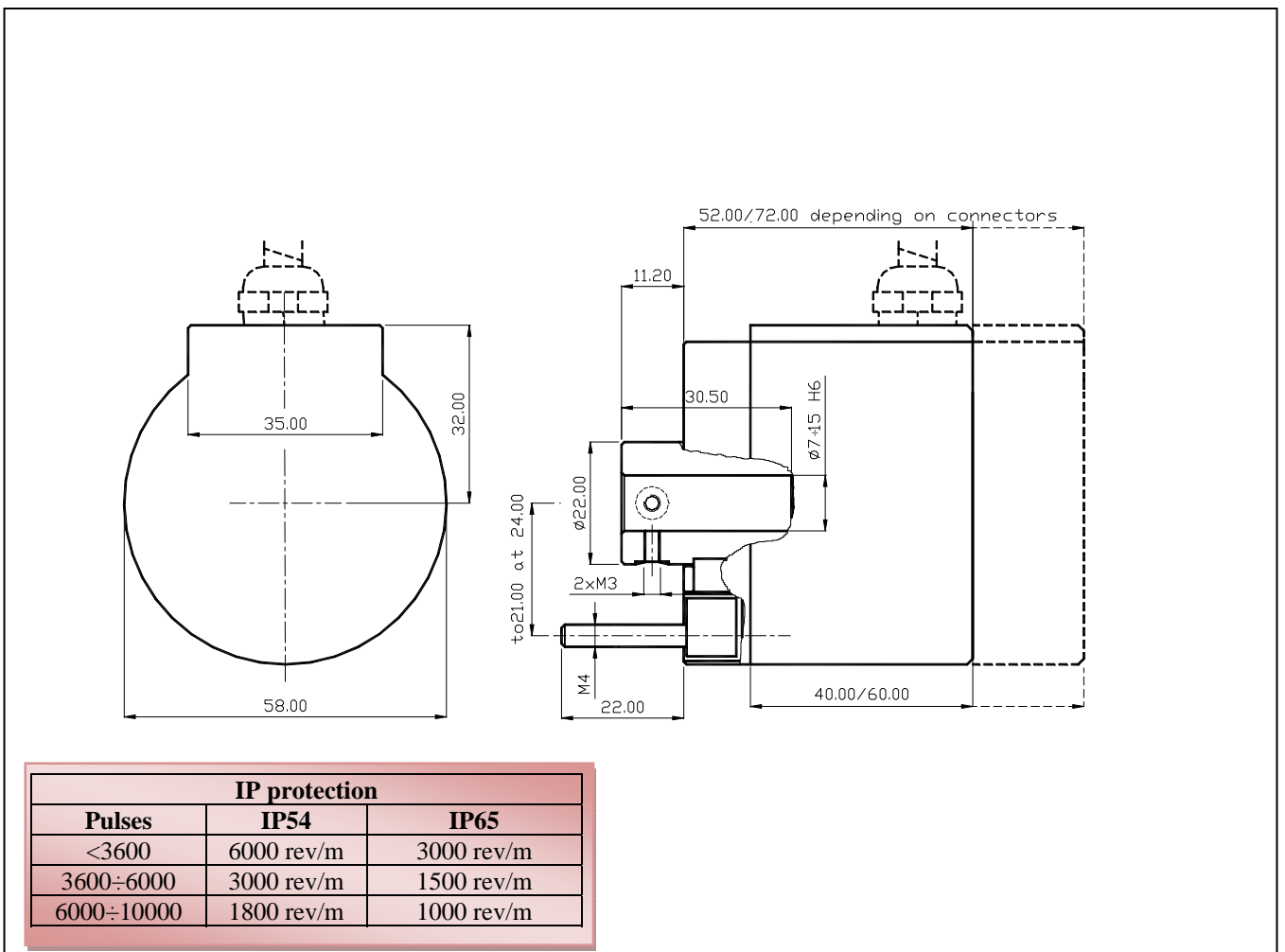

Series BS

Electronics Data

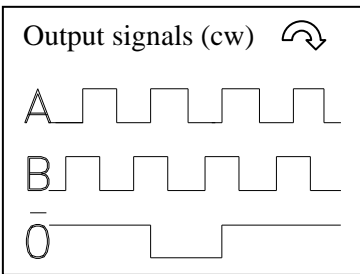

Power supply: from 5 to 24V depends on the electronics circuit
 Current consumption: 40/80mA depends on the electronics circuit
 Permissible load: 40mA
 Frequency: 100KHz
 Protections: Against short circuit, reversal polarity
 Operating Temp.: -20/+60°C

Ordering code

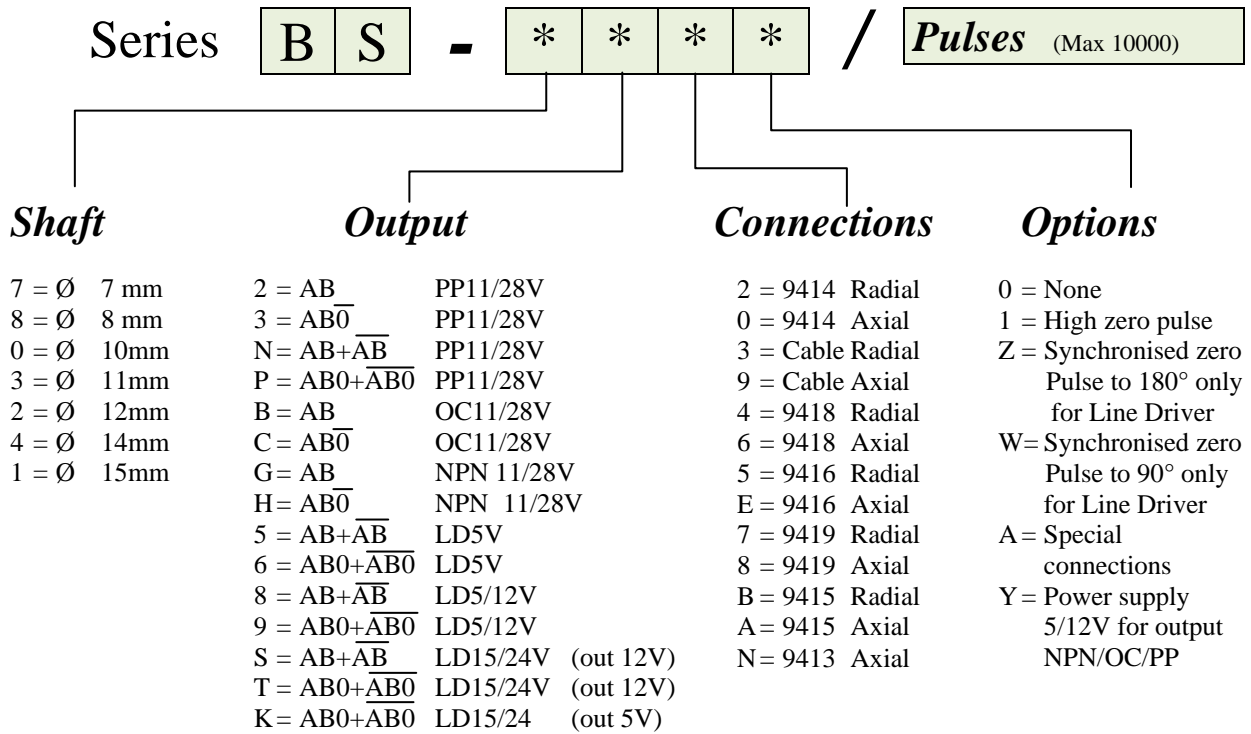

Connections

	0 Volt	+ Volt	A	B	\bar{A}	\bar{B}	0	$\bar{0}$
Cable 5 Way	White	Brown	Green	Yellow				Gray
Cable 8 Way	Black	Blue	Brown	Beige	Green	Yellow	Pink	Violet
Connector 9414	Pin1	Pin2	Pin3	Pin4				Pin5
Connector 9416-9415-9413	Pin1	Pin2	Pin3	Pin4	Pin5	Pin6	Pin7	Pin8
Connector 9418	PinA	PinB	PinC	PinD	PinE	PinF		PinG
Connector 9419	PinA	PinB	PinC	PinD	PinE	PinF	PinG	PinH