

# Series H

## Incremental shaft encoder, high resolution



### Mechanics Data

Cover:	Aluminium
Body:	Aluminium
Solid shaft:	Stainless steel
Bearings:	2, ballraces
Weight:	Approx.300gr.
Protection:	IP65
Rpm:	6000 Max
Torque:	5Ncm
Inertia:	100gcm <sup>2</sup>
Shaft loading:	Axial 100N - Radial 100N (the value decrease when the number of pulses increase)

Dimensions in mm.

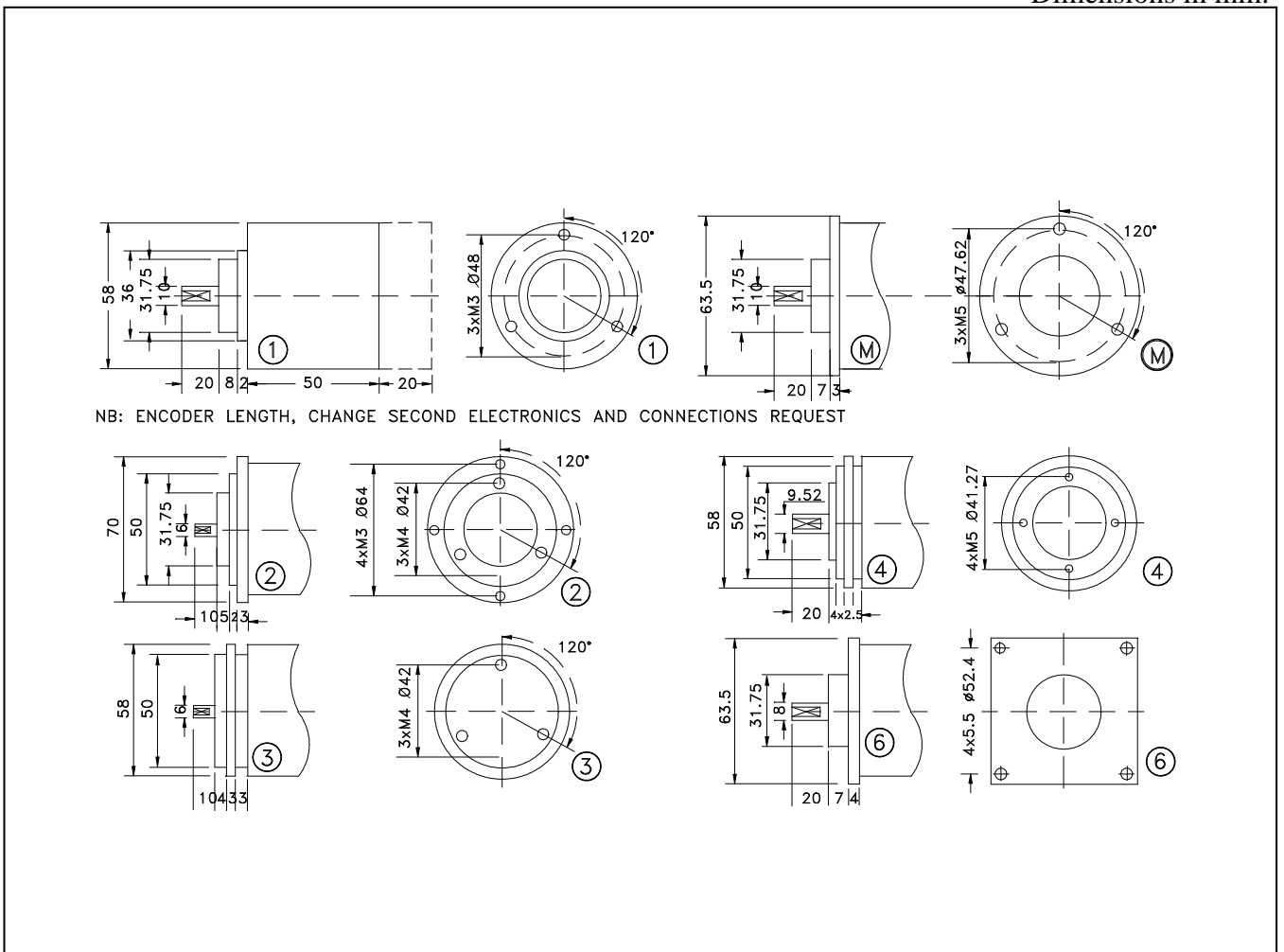

# Series H

## Electronics Data

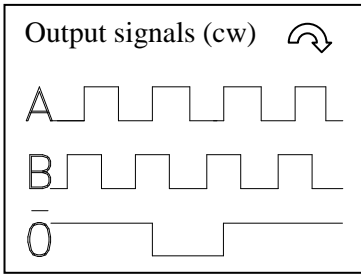

Power supply: from 5 to 24V depends on the electronics circuit  
 Current consumption: 40/80mA depends on the electronics circuit  
 Permissible load: 40mA  
 Frequency: to 600KHz depends on the electronics circuit (100 KHz sinusoidal version)  
 Protections: Against short circuit, reversal polarity  
 Operating Temp.: -20/+60°C (-30/+100°C) on request  
 0/+60° sinusoidal version

### Ordering code

Series **H** - \* \* \* \* \* / **Pulses** (Max 36.000)  
 See page pulses

#### Shaft

3 = Ø6mm  
 6 = Ø8mm  
 4 = Ø9.52mm  
 1 = Ø10mm  
 On request  
 2 = Ø12mm

#### Flange

1 =  
 2 = see  
 3 = previous  
 4 = page  
 6 =  
 M =

#### Outputs

2 = AB PP11/28V  
 3 = AB $\bar{0}$  PP11/28V  
 N = AB+AB PP11/28V  
 P = AB0+AB $\bar{0}$  PP11/28V  
 B = AB OC11/28V  
 C = AB $\bar{0}$  OC11/28V  
 G = AB NPN 11/28V  
 H = AB $\bar{0}$  NPN 11/28V  
 5 = AB+AB LD5V  
 6 = AB0+AB $\bar{0}$  LD5V  
 8 = AB+AB LD5/12V  
 9 = AB0+AB $\bar{0}$  LD5/12V  
 S = AB+AB LD15/24V(out 12V)  
 T = AB0+AB $\bar{0}$  LD15/24V(out 12V)  
 K = AB0+AB $\bar{0}$  LD15/24 (out 5V)  
 W = AB0+AB $\bar{0}$  1Vpp (Sin-Cos)  
 Y = AB0+AB $\bar{0}$  1Vpp (pulses)(Sin-Cos)  
 CD+CD 1Vpp (1 pulse)(Sin-Cos)

#### Connections

2 = 9414 Radial  
 0 = 9414 Axial  
 3 = Cable Radial  
 9 = Cable Axial  
 4 = 9418 Radial  
 6 = 9418 Axial  
 5 = 9416 Radial  
 E = 9416 Axial  
 7 = 9419 Radial  
 8 = 9419 Axial  
 B = 9415 Radial  
 A = 9415 Axial  
 N = 9413 Axial

#### Options

0 = None  
 1 = High zero pulse  
 Z = Synchronised zero Pulse to 180° only for Line Driver  
 W = Synchronised zero Pulse to 90° only for Line Driver  
 A = Special connections  
 Y = Power supply 5/12V for output NPN/OC/PP  
 U = Power supply 5/30V outputs PP  
 Sin-Cos version  
 S = 5 Volt  
 T = 8/24 Volt

**Option U:** outputs levels compatible TTL · Low level output <0.5V · High level output > +VCC-1,9V

### Connections

	0 Volt	+ Volt	A	B	$\bar{A}$	$\bar{B}$	0	$\bar{0}$
<b>Cable 5 Pole</b>	White	Brown	Green	Yellow				Gray
<b>Cable 8 Pole</b>	Black	Blue	Brown	Beige	Green	Yellow	Pink	Violet
<b>Connector 9414</b>	Pin1	Pin2	Pin3	Pin4				Pin5
<b>Connector 9416-9415-9413</b>	Pin1	Pin2	Pin3	Pin4	Pin5	Pin6	Pin7	Pin8
<b>Connector 9418</b>	PinA	PinB	PinC	PinD	PinE	PinF		PinG
<b>Connector 9419</b>	PinA	PinB	PinC	PinD	PinE	PinF	PinG	PinH