

Series CS30 absolute 4...20mA heavy duty shaft encoder up to 12mm

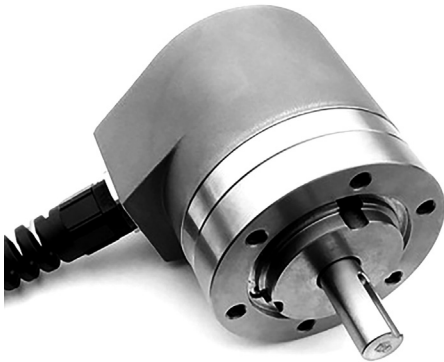

3 X K 1 - X X X X - 0 3 6 0

Protection
D = IP66/X7 SS

Output Type
34 = 3 wire, standard
66 = 2 wire, not certified

Exit
A = Axial
R = Radial

Resolution
See under technical data

Connection
1 = 2 m cable
2 = 5 m cable
F = 4 pin plug (not for IP66)



Zone 0, Class 1 Div 1

Technical Data

Operating temp:	- 20 ...+ 60 degrees C - 4 ...+ 140 degrees F
On request:	-20 ... + 100 degrees C
Current consumption:	80 mA (max.)
Power supply:	24V
Weight:	42 oz (1.2 kg)
Housing:	Stainless Steel
Shaft:	Stainless Steel
Bearings:	2 x 6001 ZZ
Torque:	0.4 oz/in (3 N-cm)
Humidity:	Up to 98% permissible
Speed:	3000 RPM max.
Shaft load:	Radial / Axial 10 N

Connection Options

2 wire version		
+ Loop	4 pin plug	Cable
- Loop	1	Red
	2	Black

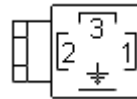

3 wire version (standard)

	4 pin plug	Cable
PS GND	1	Black
PS +24V	2	Red
Output 4...20mA	3	White

Resolution

Intrinsically Safe version: (10 bits)

0360 = 1024 counts per current ramp	1 ramp per turn (360 degrees per ramp)
0180 = 512 counts per current ramp	2 ramps per turn (180 degrees per ramp)
0090 = 256 counts per current ramp	4 ramps per turn (90 degrees per ramp)

Non-intrinsically Safe version: (12 bits)

0360 = 4096 counts per current ramp	1 ramp per turn (360 degrees per ramp)
0180 = 2048 counts per current ramp	2 ramps per turn (180 degrees per ramp)
0090 = 1024 counts per current ramp	4 ramps per turn (90 degrees per ramp)

Output

Count will increment in CW direction.

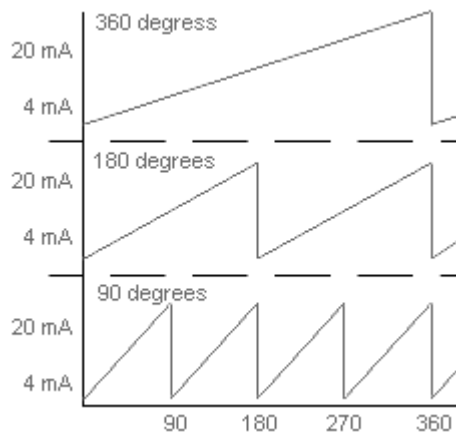

*4...20mA span based on 250 ohm load

Certifications

Best suited to work with the following isolators: [MTL5541](#)

ATEX

IECEX

CSA

GOST (CU)

Mounting Instructions

To mount encoder on machine: Option 1 is to mount with three screws, option 2 is to use synchroflange mounting brackets. Hook up the encoder with the connections as described. Make sure power supply meets specifications. Attach encoder to mounting bracket as shown. Attach shaft using a flexible coupling.

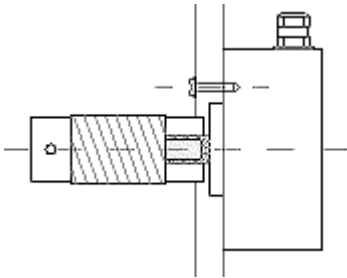

Dimensions (3 wire version)

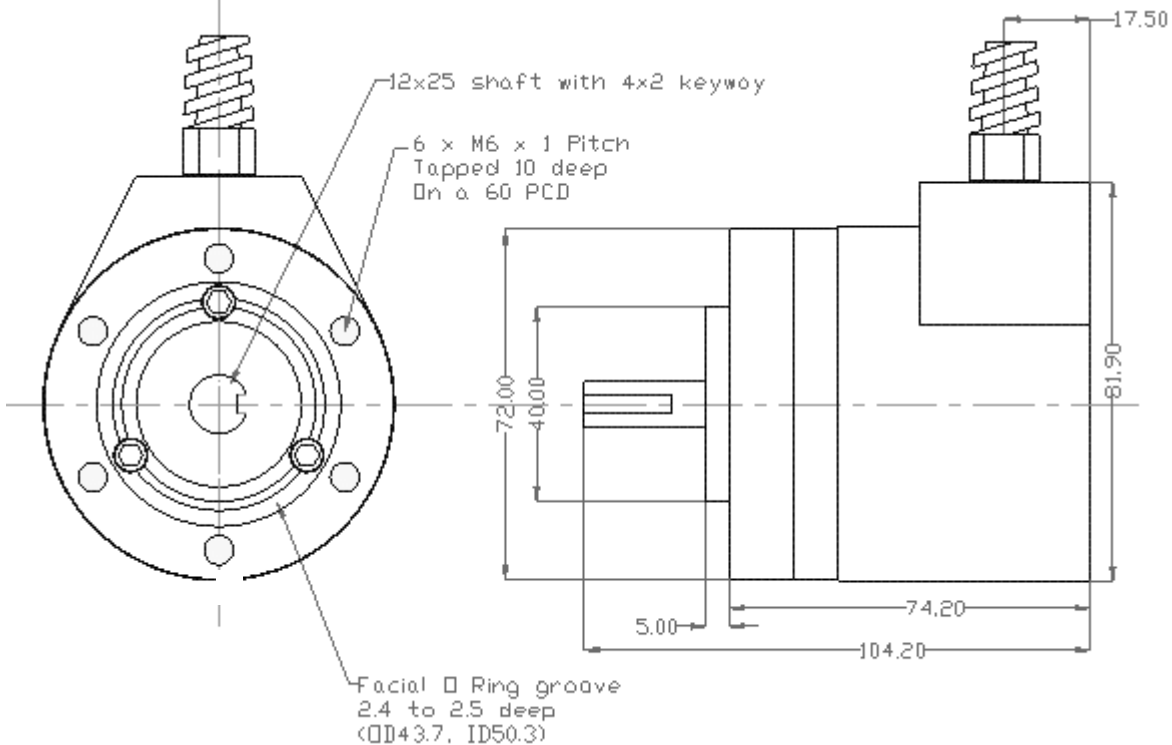

Dimensions (2 wire version)

