

# **hohner**

Elektrotechnik Werne

## **Hohner Rotary Encoders**

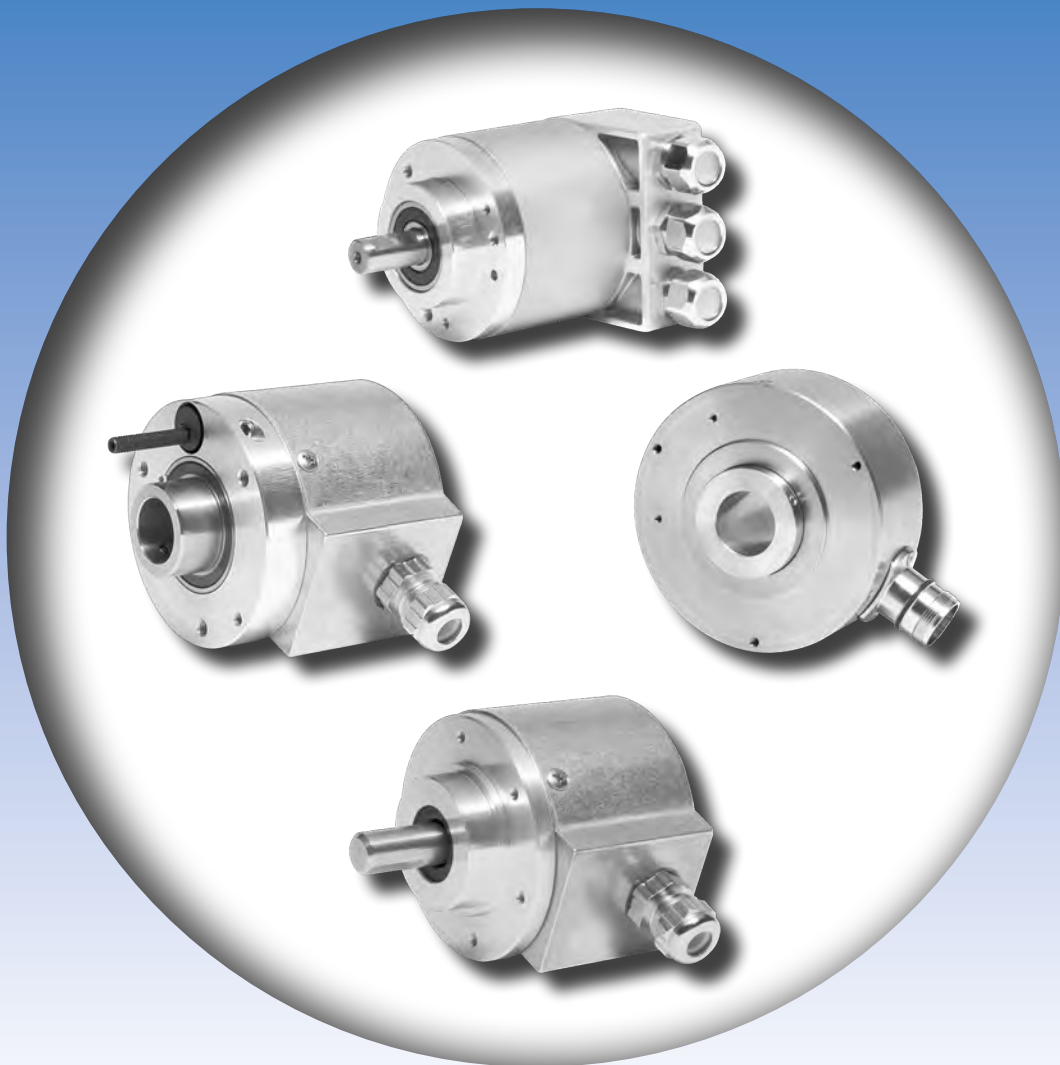

Absolute Single- and Multiturn · Incremental · Parallel · SSI  
InterBus-S · CAN · CANopen · Profibus-DP  
DeviceNet · ProfiNet · EtherNet

Your partner for standard and special designs  
– accurate, reliable and quick –

## About us

---

Hohner Elektrotechnik GmbH was founded in 1980 in Werne an der Lippe, a beautiful small town on the edge of the Münsterland.

Hohner has been a specialist in the design and manufacture of pulse encoders and its associated application possibilities. Therefore, to this day, the main task of the company still consists of producing high-quality products and, above all, putting reliable Hohner products on the market.

In order to meet the ever increasing market requirements, optimum logistics ensure short delivery times.

## Pulse encoders - Function and benefits

---

Incremental and absolute rotary encoders are used to measure angles, distances and speeds. They serve thus as an interface between the mechanically and electrically measured variable in a control loop, and are mainly used in automation technology. The electrically measured variable generated is prepared in such a way that it can be evaluated directly by the PLC (Programmable Logic Controller), a control computer or even a simple counter card.

A contactless optical scanning of a measuring body (pulse disc) in transmitted light procedure applies to all Hohner encoders.

An LED emits infrared light through a sampling grid. By moving the measurement body, the light is interrupted rhythmically and measured via receiver elements. The downstream electronics shapes and amplifies the signals thus generated. Dividing the measuring body into a certain number of equal parts (increments) enables optimum evaluation.

Hohner uses as measuring body high-grade plastic pulse discs with extremely high temperature resistance and high shock resistance.

The scale is attached onto the plastic carrier with a special photo-technical procedure designed by Hohner. This technology allows the production of any number of pulses or division to the maximum value of the respective series.

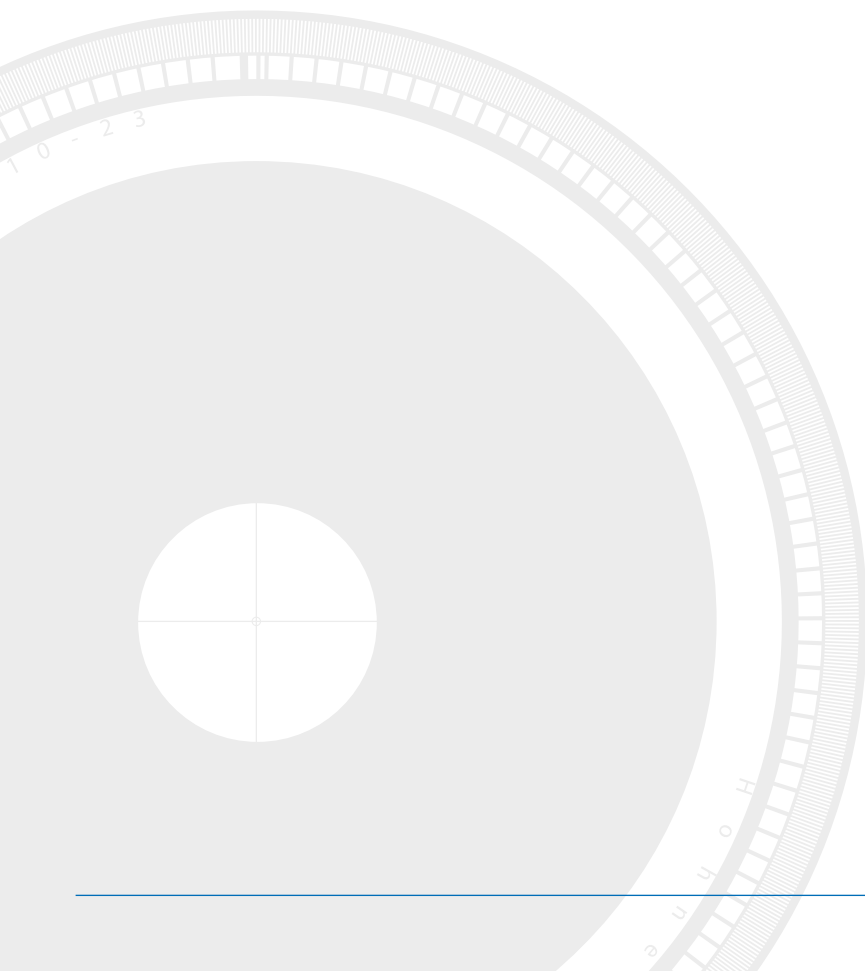

## Incremental rotary encoders

General description	4
Solid shaft encoders	
Series 20	8
Series AWI 40	10
Series AWI 58	12
Series AWI 58 H	14
Series AWI 90	16
Series AWI 90 Redundant	18
Series PH 05	20
Series PA 02	22
Blind hollow shaft encoders	
Series SWI 58	24
Hollow shaft encoders	
Series HWI 40	26
Series HWI 58	28
Series HWI 80	30
Series HWI 103	32
Series MIG Nova	34
Ex encoder of the type EEx d IIC T6	
Series AWI 70 Ex & HWI 70 Ex	38

## Absolute rotary encoders

General description	42
Solid shaft encoders	
Series AWA 58	46
Series AWA 90	48
Series 70 –140	50
Multiturn solid and blind hollow encoders	
Series 72	52
Series BC 58	56
Series PS & Series PSM	66
Hollow shaft encoders	
Series HWA 103	68
Series SWA 90	70
Ex encoder of the type II 2 G Ex d IIC T6	
Series AWA 70 Ex & Series HWA 70 Ex	72

## Linear measuring system

Draw wire Series EM	76
---------------------	----

## Accessories

Connection types	78
Torque supports	79
Measuring wheels	80
Couplings	81
Racks	81
Sprockets	81
Flanges	
Round flanges	82
Square flanges	83
Angle flanges	84
Mounting bell	85

Assembly/Installation instructions	86
------------------------------------	----

EC declaration of conformity	87
------------------------------	----

General sales conditions	88
--------------------------	----

# Incremental Rotary Encoders

## General description

Incremental rotary encoders are sensors for detecting rotary movements. An optoelectronic scanning unit converts the division (circular disc with light and dark fields, also referred to as increments) supplied by a measuring body into a proportional number of electronic pulses. The number of output pulses is a measure for the angle of the encoder. The subsequent electronics used by the user enable the measuring of angles, distances or speeds. Different signal outputs and output circuits are available for adapting to the controls used.

## Signal outputs

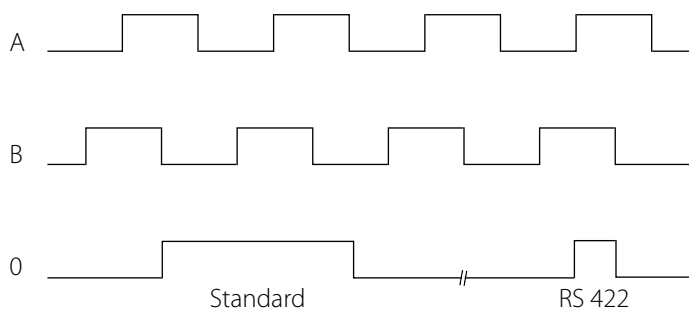

Two square pulse trains offset by 90° el, with channel A lagging in clockwise rotation.

Reference pulse 0 once per revolution, position and length optional, linked for RS 422.

All output signals measured against GND!

All channels can also be executed inversely.

## Pulse and Phase tolerance

### Puls tolerance

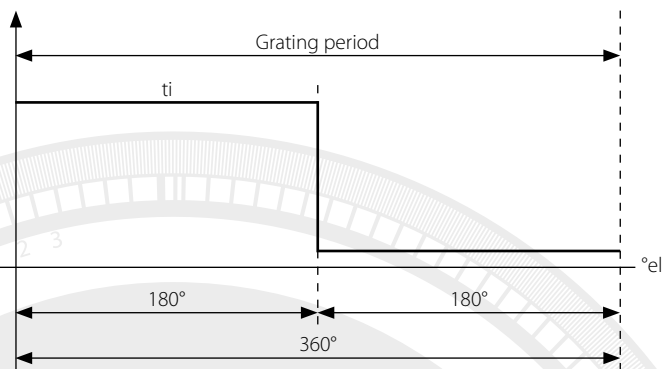

$t_i : t_p$  180° el: 180° el ± 10%

### Phase tolerance

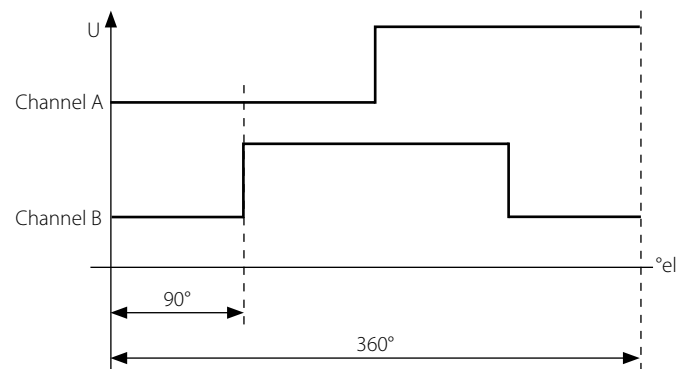

90° el ± 10%

## Calculation of permissible speed

$$n \left( \frac{u}{\min} = \frac{f_{\max} \text{ (Hz)}}{\text{No. of pulses}} \right) \times 60$$

Attention: Observe permissible mechanical speed

## Power supply

$$U_B = 5 \text{ V DC} \pm 5\%$$

$$U_B = 10 \text{ V} \dots 30 \text{ V DC}$$

The limits of supply voltage, including the residual ripple, may not be exceeded as this could cause malfunctions, or damage the device.

## Output circuits

- 0 Darlington Driver  
ULN 2003 o.ä.  
max. 40 mA per channel  
short-circuit-proof

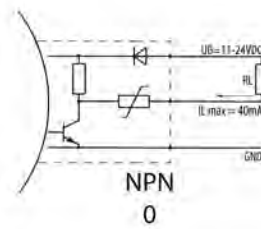

- 1 Push-pull –  
Power driver  
max. 30 mA/or 100 mA  
per channel  
short-circuit-proof

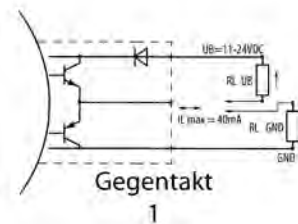

- 2 TTL Line Driver  
75114 or sim.

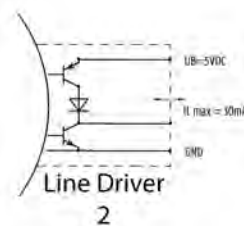

- 3 TTL  
max. 1.6 mA per channel  
(1 TTL load)

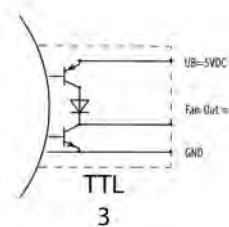

- 6 Driver according to E/A standard  
RS 422  
AM 26 LS 31 C  
DS 26 C 31 C or sim.

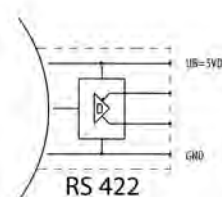

# Incremental Rotary Encoders

## Alarm output

Output circuit

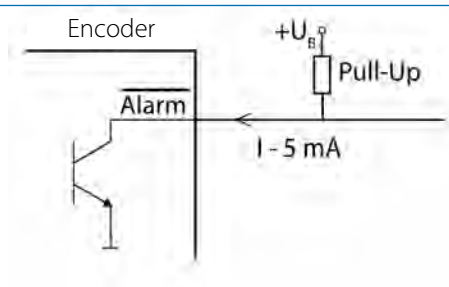

## Technical data

<b>Output</b>	NPN - Open collector
<b>Output load max.</b>	5 mA/24 V at $U_B = 5 \text{ V DC}$ 5 mA/32 V at $U_B = 10 \dots 30 \text{ V DC}$
<b>Level</b>	Output active (fault): L 0.7 V DC Output inactive: high impedance (H level, possibly via external pull-up resistor)
<b>Error reporting period</b>	• 20 ms

## Function

The rotary encoders with alarm outputs are equipped with monitoring electronics reporting essential operating errors via a separate output. The alarm output can be used for selecting an optical control (LED; for circuit, see above) or the control system (PLC or similar). The alarm outputs of several encoders can also be interconnected by parallel connection to a common "System alarm".

The following errors are reported:

Category I	Category II	Category III
- Glass breakage	- Overtemperature $1 \text{ V DC} < U < 4 \text{ V DC}$	Voltage range
- Defective LED	- Overload e.g. due to short circuit	- Voltage drop on the supply lines
- Contamination		

**Category I errors** cannot be remedied; replacing the encoder is necessary.

**Category II errors** are detected by means of a thermal monitoring unit in the electronics. The error message expires after removing the cause for the temperature increase.

**Category III errors** indicate an insufficient power supply. This category also reports short-term disturbances of the power supply, e.g. due to electrostatic discharges, which may distort the output signals. Remedial action ensues by intercepting the interfering effects, e.g. by carefully selecting the cable routing.

**Cable lengths (AWI 58 H)**

Output RS 422 (R)	depending on output voltage and frequency (at 25°C)	
	length	RS 422
	10 m	5 V DC, 300 kHz
	50 m	5 V DC, 300 kHz
	100 m	5 V DC, 300 kHz

Output Push-pull (K)	depending on output voltage and frequency (at 25°C)		
	length	Push-pull (K)	Push-pull (K)
		5 V DC, 10 mA	10...30 V DC, 30 mA
	10 m	300 kHz	12 V DC, 200 kHz 24 V DC, 200 kHz 30 V DC, 200 kHz
	50 m		12 V DC, 200 kHz 24 V DC, 200 kHz 30 V DC, 100 kHz
	100 m		12 V DC, 200 kHz 24 V DC, 100 kHz 30 V DC, 50 kHz

Output Push-pull antivalent (I)	depending on output voltage and frequency (at 25°C)	
	length	Push-pull antivalent
	10 m	12 V DC, 200 kHz 24 V DC, 200 kHz 30 V DC, 200 kHz
	50 m	12 V DC, 200 kHz 24 V DC, 50 kHz 30 V DC, 25 kHz
	100 m	12 V DC, 150 kHz 24 V DC, 25 kHz 30 V DC, 12 kHz

# Series 20

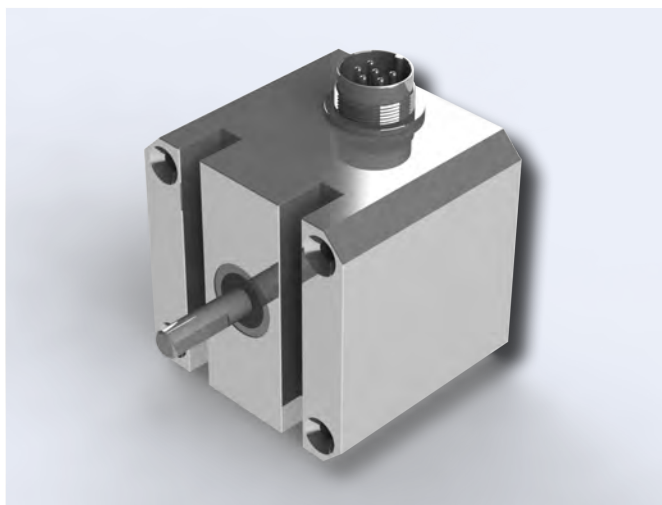

## Series 20

- ▶ Incremental rotary-encoder with a solid shaft diameter of 6mm
- ▶ Square housing, small design and normal degree of protection
- ▶ Maximum 1.024 pulses / revolution
- ▶ For simple industrial requirements
- ▶ Accessories from page 78

### Electrical specifications

max. pulse frequency:	25 kHz
Perm. temperature range:	-30° ... +70° C
Power supply:	10 V ... 30 V DC
Max. current consumption:	80 mA (without load)
Max. output load:	30 mA (per channel)
Residual ripple:	max. $\pm 5\% U_B$
Power supply:	5 V DC $\pm 5\%$
Max. current consumption:	80 mA

### Mechanical specifications

Housing/Flange:	Zinc die-casting - cadmium-plated
Shaft:	stainless steel
Bearing:	Deep groove ball bearing
Weight:	approx 0,5 kg
Protection type:	IP 41 according to DIN 40050
Max. speed:	3.000 U/min
Moment of inertia:	10 gcm <sup>2</sup>
Torque:	approx 0,4 Ncm
Max. shaft load:	axial 5 N radial 3 N

### Mechanical dimensions

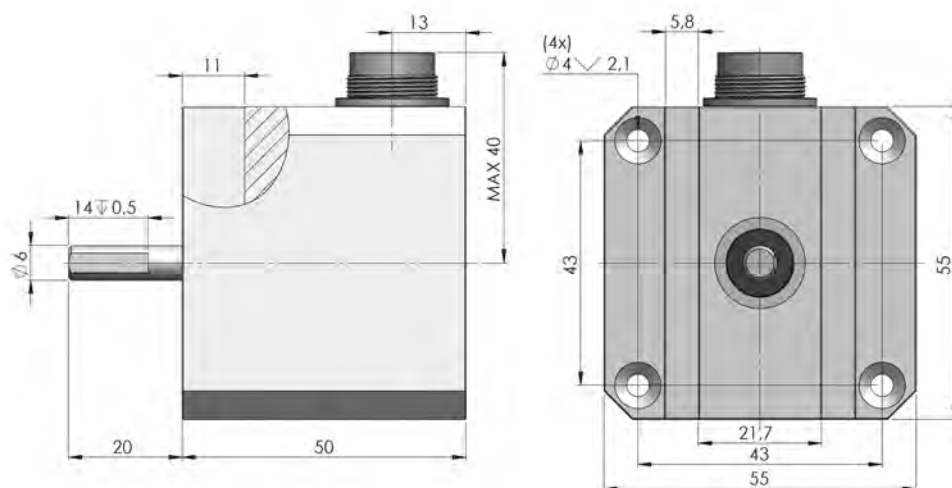



Output circuits

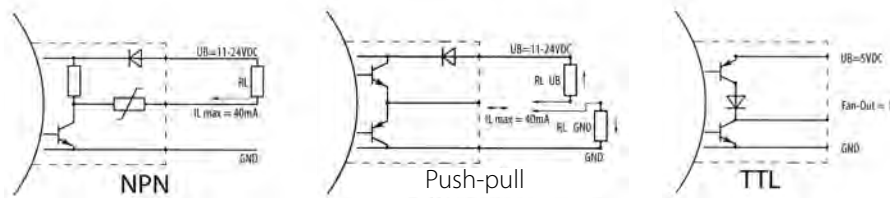

Order ref.: 0

1

3

Signal outputs

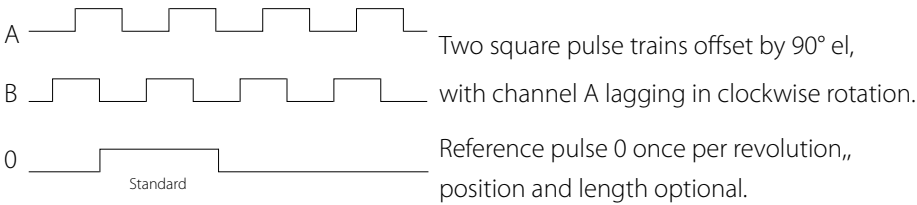

All channels can also be executed inversely.

Pin configuration

	- Volts	+ Volts	A	B	0
Connection type 5-core cable	black	blue	brown	beige	yellow
Connection type 9414/08 connector	Pin 1	Pin 2	Pin 3	Pin 4	Pin 5
Connection type 9412/05 connector	Pin 1	Pin 2	Pin 3	Pin 4	-

Order reference

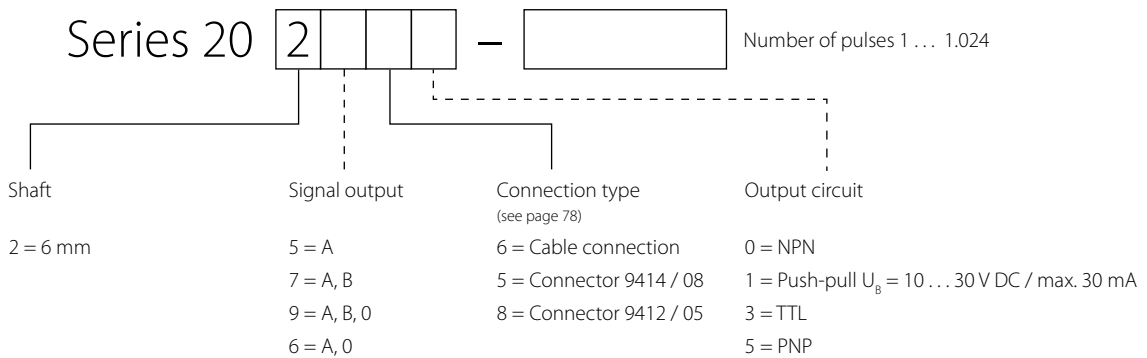

# Series AWI 40

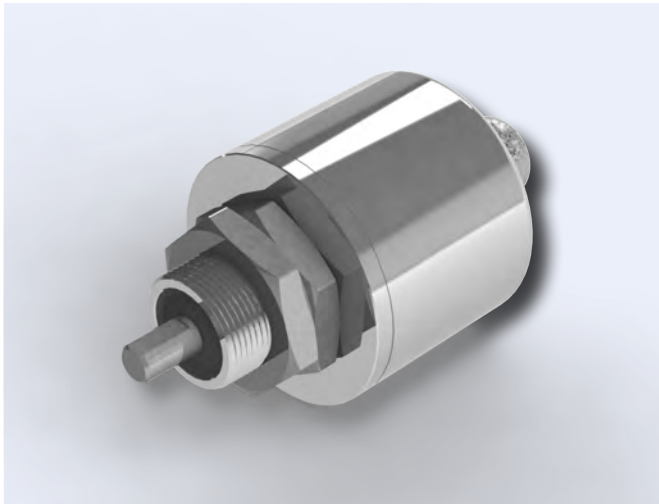

## Series AWI 40

- ▶ Incremental rotary-encoder with a solid shaft diameter of 6 mm
- ▶ housing diameter 40 mm, small design and high degree of protection
- ▶ Maximum 1024 pulses / revolution
- ▶ For simple industrial requirements
- ▶ Also available in stainless steel for aggressive Ambient conditions
- ▶ Accessories from page 78

### Electrical specifications

max. pulse frequency:	25 kHz
Perm. temperature range:	-30°... +70°C
Power supply:	10 V... 30 V DC
Max. current consumption:	80 mA (without load)
Max. output load:	30 mA (per channel)
Residual ripple:	max. $\pm 5\% U_B$
Power supply:	5 V DC $\pm 5\%$
Max. current consumption:	40 mA
Max. output load:	30 mA (per channel)

### Mechanical specifications

Flange/Housing:	Aluminium
Shaft:	stainless steel
Shaft seal:	oil/salt-water resistant
Bearing:	Deep groove ball bearing
Weight:	approx 0,3 kg
Protection type:	IP 65
Max. speed:	6.000 U/min
Torque:	approx 3 Ncm
Max. shaft load:	axial 5 N radial 5 N

### Mechanical dimensions

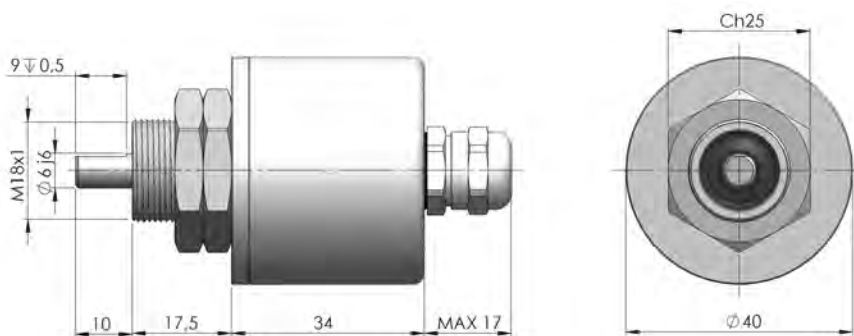

### Output circuits

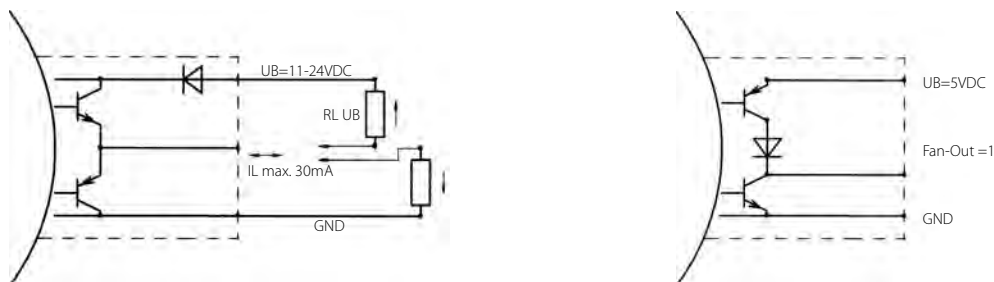

### Signal outputs

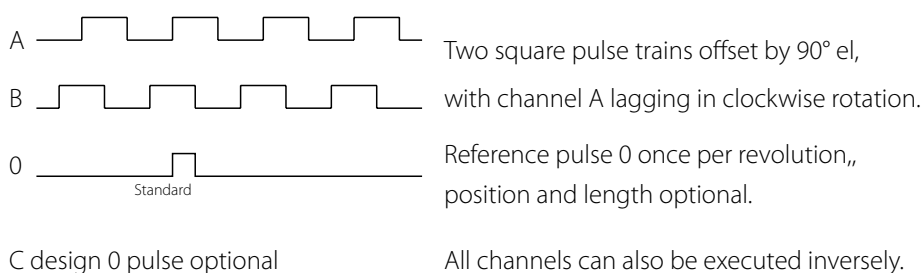

### Tolerances (at 25 kHz)

Phase offset:  $90^\circ \pm 20^\circ$  el      Duty cycle:  $180^\circ : 180^\circ \pm 18^\circ$  el

### Pin configuration

	GND	+ U <sub>B</sub>	A	B	Ā	B̄	0	0̄
Connection type 00 (Colour code according to DIN 47100)	white	brown	green	yellow			gray	
Connection type 00 (Colour code according to DIN 47100)	white	brown	green	yellow	gray	pink	blue	red
Connection type 01	black	blue	brown	beige			yellow	
Connection type 01	black	blue	brown	beige	yellow	green	pink	purple
Connection type 08, 09	1	2	3	4	(5)		5	
Connection type 10, 11	1	2	3	4	(5)	(6)	5	6

### Order reference

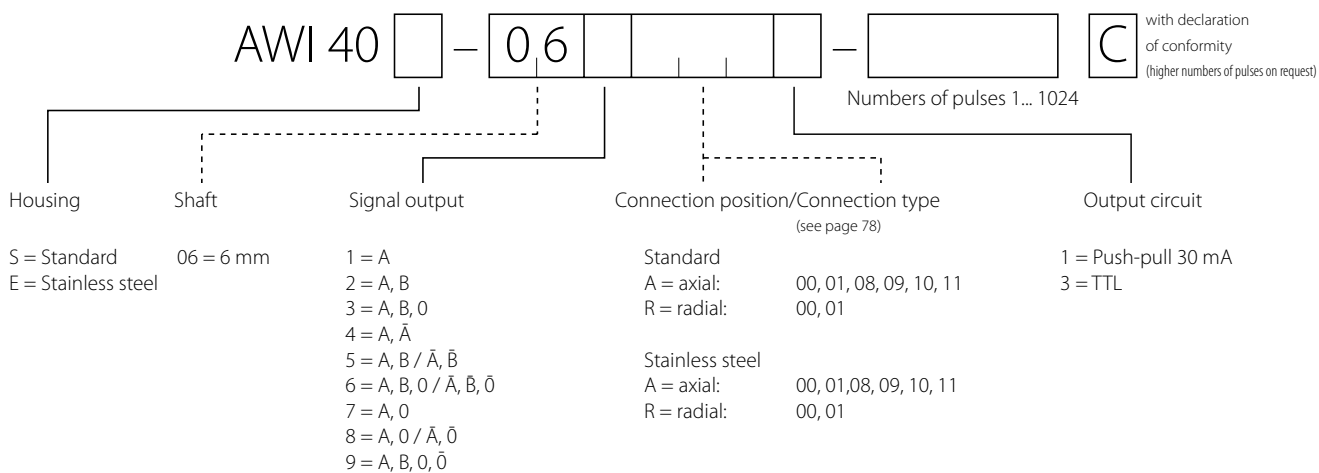

# Series AWI 58

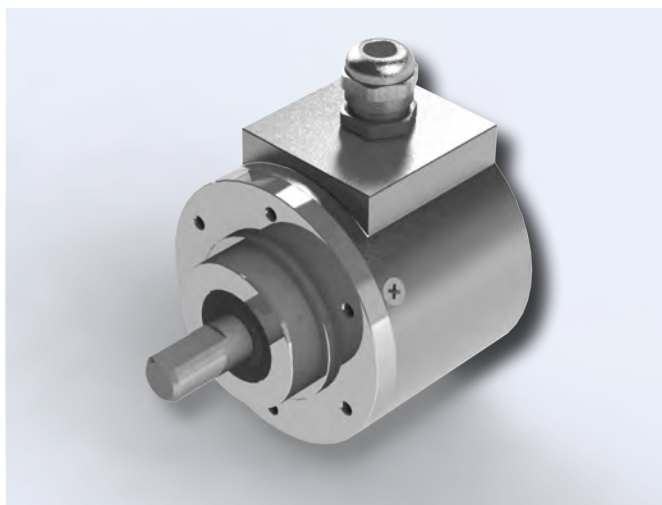

## Series AWI 58

- ▶ Incremental rotary-encoder with a solid shaft diameter of 6-12 mm
- ▶ Housing diameter 58 mm, compact design and high degree of protection up to IP67
- ▶ Maximum 5.000 pulses / revolution
- ▶ For highest industrial requirements
- ▶ Also available in stainless steel for aggressive environmental conditions
- ▶ Accessories from page 78

### Electrical specifications

max. pulse frequency:	100 kHz
Perm. temperature range:	-30° ... +70° C
Power supply:	10 V ... 30 V DC
Max. current consumption:	80 mA (without load)
Max. output load:	30 mA (per channel)
Residual ripple:	max. ± 5% UB
Power supply:	5 V DC ± 5%
Max. current consumption:	80 mA
Max. output load:	30 mA (per channel)

### Mechanical specifications

Flange:	Aluminium
Housing:	Zinc die-casting
Shaft:	stainless steel
Shaft seal:	oil/salt-water resistant
Bearing:	Deep groove ball bearing
Weight:	approx 0,4 kg
Protection type:	IP 65
Max. speed:	6.000 U/min
Torque:	approx 3 Ncm
Max. shaft load:	axial 15 N/radial 30 N

### Mechanical dimensions

A	B	C
6 mm	10 mm	9.5 mm
6.35 mm	10 mm	9.5 mm
8 mm	20 mm	15 mm
9.52 mm	20 mm	15 mm
10 mm	20 mm	15 mm
12 mm	25 mm	20 mm

\* Tolerance = fg 6

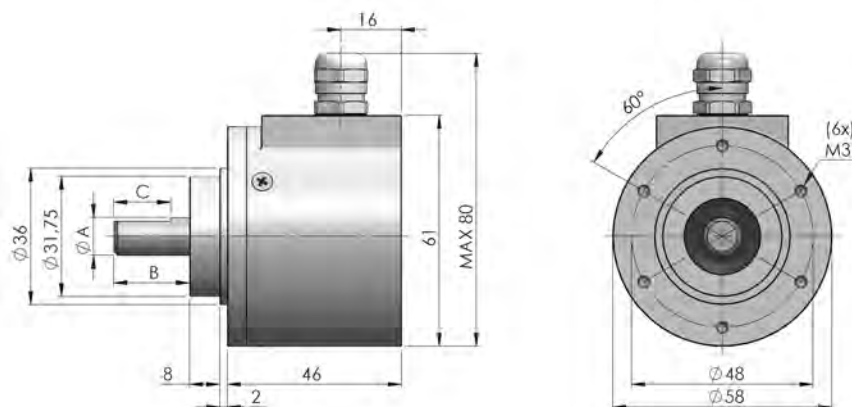

### Output circuits

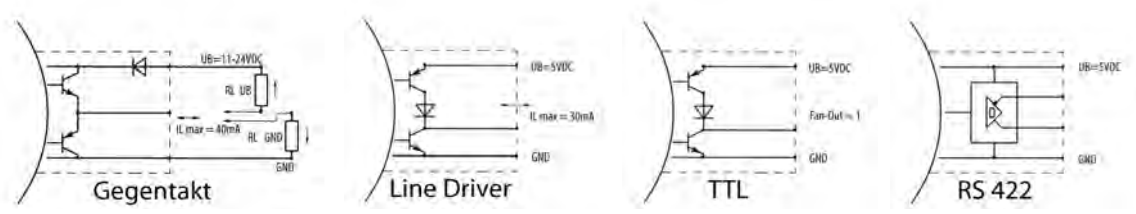

Order ref.: 1 2 3 6

### Signal outputs

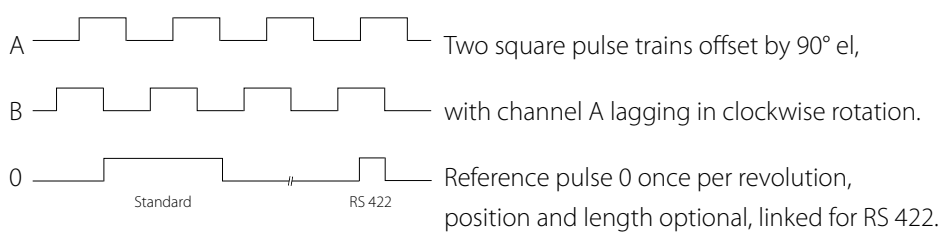

All channels can also be executed inversely.

### Pin configuration

	GND	+ U <sub>B</sub>	A	B	$\bar{A}$	$\bar{B}$	0	$\bar{0}$
Connection type 00 (Colour code according to DIN 47100)	white	brown	green	yellow			gray	
Connection type 00 (Colour code according to DIN 47100)	white	brown	green	yellow	gray	pink	blue	red
Connection type 01	black	blue	brown	beige			yellow	
Connection type 01	black	blue	brown	beige	yellow	green	pink	purple
Connection type 05	1	2	3	4				
Connection type 08, 09	1	2	3	4	(5)		5	
Connection type 10, 11	1	2	3	4	(5)	(6)	5	6
Connection type 12	1	2	3	4	5	6	7	8
Connection type 52	A	B	C	D	E	F	G	

### Order reference

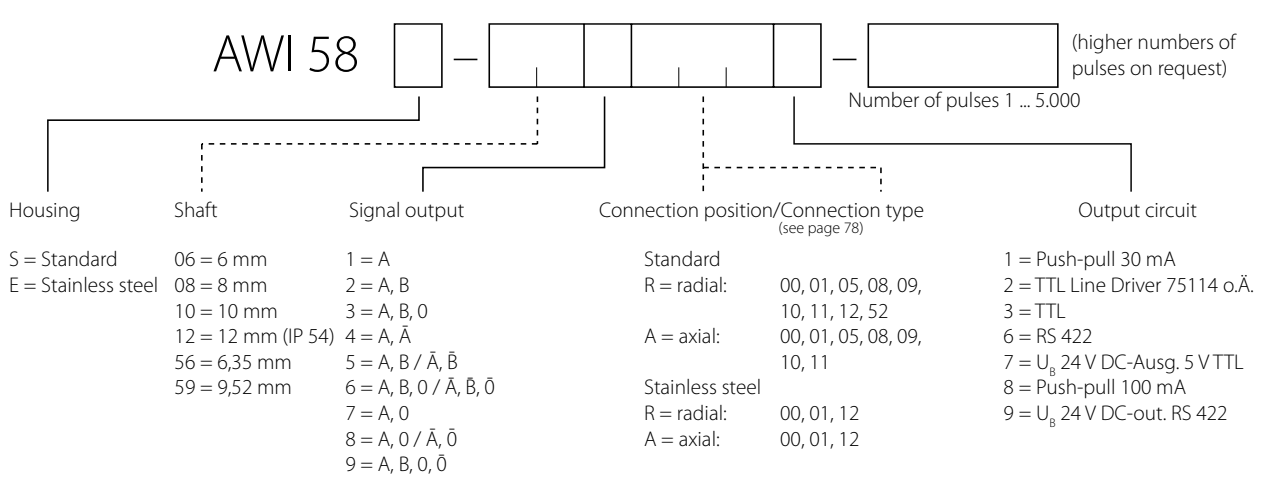

# Series AWI 58 H

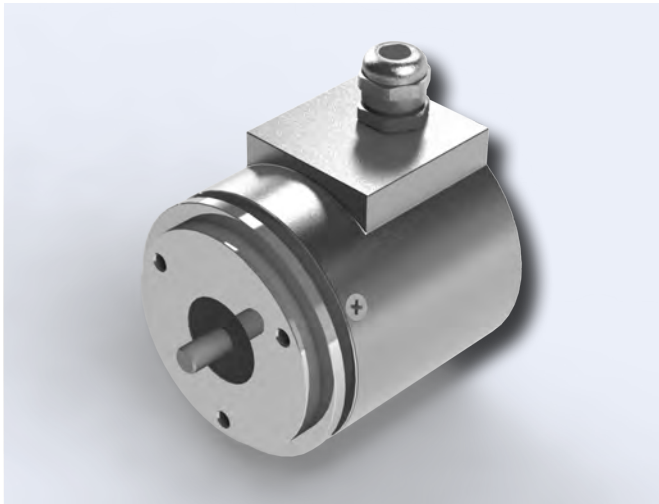

## Series AWI 58 H

- ▶ Incremental rotary-encoder with a solid shaft diameter of 6-12 mm
- ▶ Housing diameter 58mm, compact design and high degree of protection up to IP67
- ▶ Maximum 90.000 pulses / revolution
- ▶ For highest industrial requirements
- ▶ Also available in stainless steel for aggressive environmental conditions
- ▶ Accessories from page 78

### Electrical specifications

General design	according to DIN VDE 0160, protection class III, degree of contamination 2, overvoltage category II
max. pulse frequency:	200 kHz (Push-pull) 300 kHz (RS 422)
Perm. temperature range:	-30° ... +70° C
Power supply:	10 ... 30 V DC* (Push-pull (K, I)) 5 V ± 10% or 10 ... 30 V DC* (RS 422 + (R))
Current consumption:	40 mA (5 V DC) 60 mA (10 V DC) 30 mA (24 V DC)

\* Reverse polarity protection for supply voltage 10 ... 30 V DC

### Mechanical specifications

Flange:	S = Synchro flange, K = Clamping flange
Housing:	Aluminium Ø 58 mm
Shaft:	stainless steel
Shaft diameter:	6 mm / 10 mm
Weight:	approx 0,4 kg
Protection class (EN60529):	IP 65 or IP 67
Max. speed:	10.000 U/min
Torque:	0,5 Ncm (IP 65) / 1 Ncm (IP 67)
Max. shaft load:	Ø 10 mm radial 60 N/axial 40 N Ø 6 mm radial 40 N/axial 20 N
Moment of inertia:	S = Synchro flange approx 14 g/cm <sup>2</sup> K = Clamping flange approx 20 g/cm <sup>2</sup>
Vibration resistance:	100 m/s <sup>2</sup> (10...2.000 Hz) (DIN EN 60068-2-6)
Shock resistance:	1.000 m/s <sup>2</sup> (6 ms) (DIN EN 60068-2-27)
Connection type:	1,5 m cable or flange receptacle

### Mechanical dimensions

#### Synchro flange, 58 mm

L1 max. = 57.5 mm  
L2 max. = 56 mm

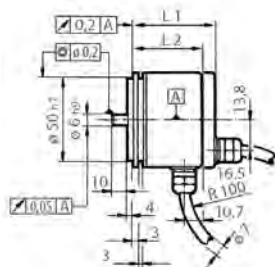

#### Clamping flange, 58 mm

L1 max. = 57.5 mm  
L2 max. = 56 mm

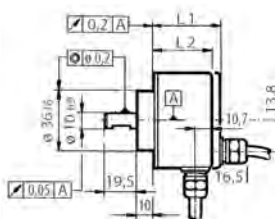

All specification in millimeters

Connection cable, axial/radial

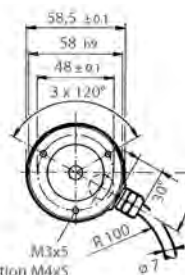
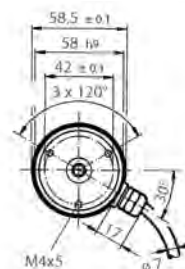

Flange receptacle, 12-pol, axial/radial

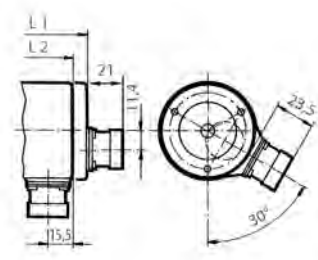
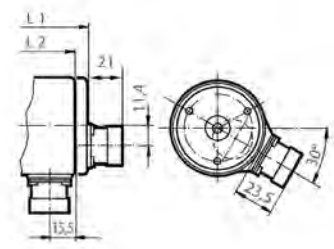

**Pin configuration cable**

Colour code 00 depending on the version	Colour code 01 depending on the version	Function
white	black	-
brown	blue	+ UB
green	brown	A
yellow	beige	B
grey	yellow	AN
pink	green	BN
blue	pink	0
red	violet	0N

**Numbers of pulses  
AWI 58 H**

From 1 to 90.000

**Flange receptacle 12-pole (clockwise)**

PIN	RS 422 (R)	Push-pull (K)	Push-pull antivalent (I)
1	Channel B-	N.C.	Channel B-
2	Sense V <sub>CC</sub>	N.C.	Sense V <sub>CC</sub>
3	Channel N	Channel N	Channel N
4	Channel N-	N.C.	Channel N-
5	Channel A	Channel A	Channel A
6	Channel A-	N.C.	Channel A-
7	N.C.	N.C.	N.C.
8	Channel B	Channel B	Channel B
9	N.C.	N.C.	N.C.
10	GND	GND	GND
11	N.C.	N.C.	N.C.
12	5/10 ... 30 V DC =	10 ... 30 V DC =	10 ... 30 V DC =

**Standard-output variants**

RS 422 (R):

A, B, N, A-, B-, N-

Push-pull (K):

A, B, N

Push-pull antivalent(I):

A, B, N, A-, B-, N-

**Order reference**

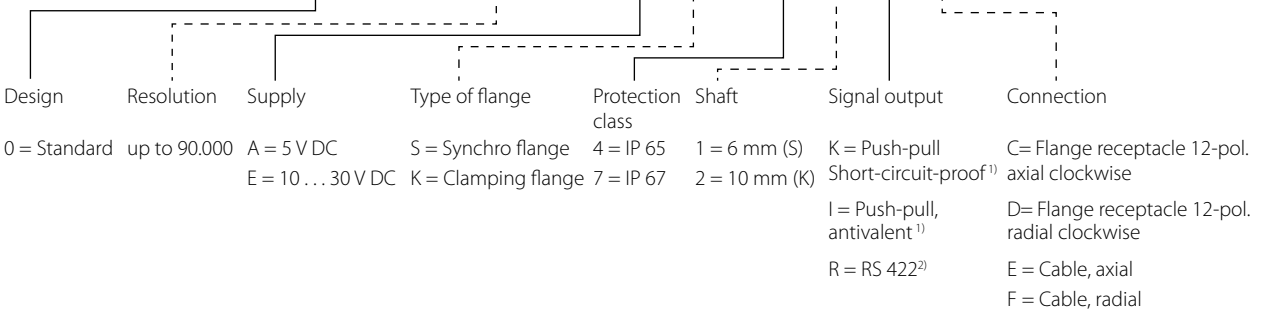

- Design: 0 = Standard
- Resolution: up to 90.000
- Supply: A = 5 V DC, E = 10 ... 30 V DC
- Type of flange: S = Synchro flange, K = Clamping flange
- Protection class: 4 = IP 65, 7 = IP 67
- Shaft: 1 = 6 mm (S), 2 = 10 mm (K)
- Signal output: K = Push-pull Short-circuit-proof<sup>1)</sup>, I = Push-pull, antivalent<sup>1)</sup>, R = RS 422<sup>2)</sup>
- Connection: C = Flange receptacle 12-pol. axial clockwise, D = Flange receptacle 12-pol. radial clockwise, E = Cable, axial, F = Cable, radial

<sup>1)</sup>Supply 10 ... 30 V DC <sup>2)</sup>Supply 5 V DC

# Series AWI 90

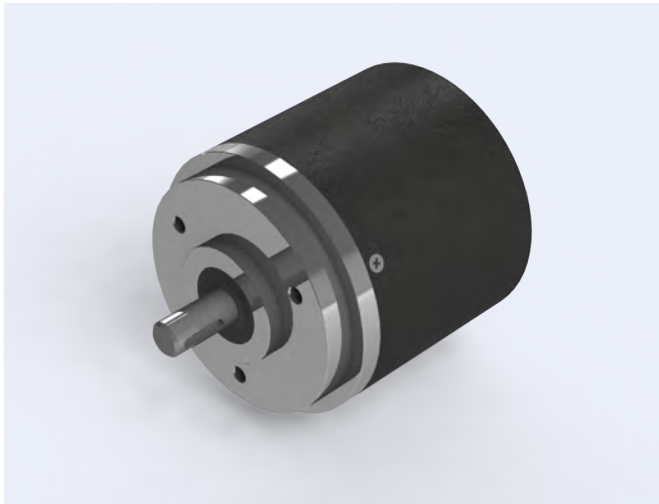

## Series AWI 90

- ▶ Incremental rotary-encoder with a solid shaft diameter of 12 mm
- ▶ Housing diameter 90mm, robust design and high degree of protection
- ▶ Maximum 5.000 pulses / revolution
- ▶ For highest industrial requirements
- ▶ Also available in stainless steel for aggressive environmental conditions
- ▶ Accessories from page 78

### Electrical specifications

Max. step frequency:	100 kHz
Perm. temperature range:	-30° ... +70° C
Power supply:	10 V ... 30 V DC
Max. current consumption:	80 mA (without load)
Max. output load:	30 mA (per channel)
Residual ripple:	max. $\pm$ 5% UB
Power supply:	5 V DC $\pm$ 5%
Max. current consumption:	80 mA 150 mA for Line Driver 75114 or sim.

### Mechanical specifications

Flange:	Aluminium
Housing:	Powder-coated sheet steel
Shaft:	stainless steel
Shaft seal:	oil/salt-water resistant
Bearing:	Deep groove ball bearing
Weight:	approx 1,2 kg
Protection type:	IP 65
Max. speed:	6.000 U/min
Torque:	approx 5 Ncm
Max. shaft load:	axial 30 N/radial 50 N

### Mechanical dimensions

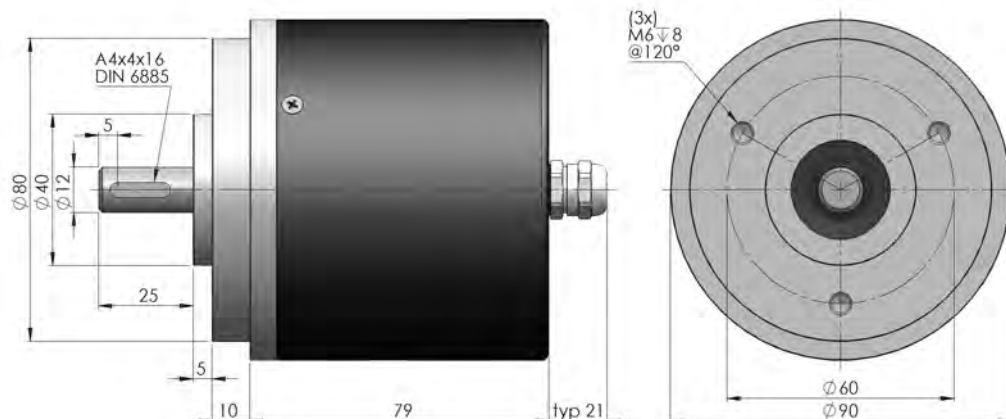

\* Tolerance = h 6



Output circuits

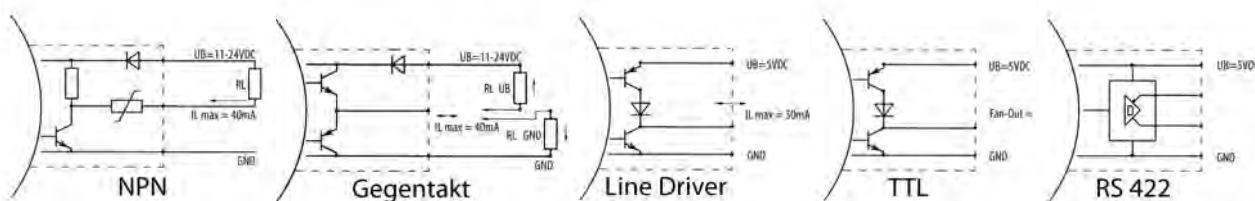

Order ref.: 0 1 2 3 6

Signal outputs

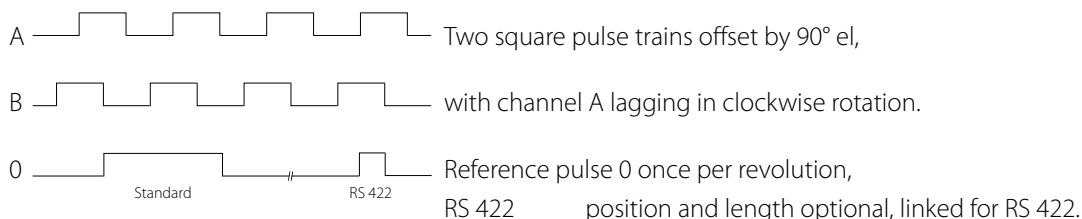

All channels can also be executed inversely.

Pin configuration

	GND	+ U <sub>B</sub>	A	B	$\bar{A}$	$\bar{B}$	0	$\bar{0}$
Connection type 00 (Colour code according to DIN 47100)	white	brown	green	yellow			gray	
Connection type 00 (Colour code according to DIN 47100)	white	brown	green	yellow	gray	pink	blue	red
Connection type 01	black	blue	brown	beige			yellow	
Connection type 01	black	blue	brown	beige	yellow	green	pink	purple
Connection type 02, 03	1	2	3	4	5	6	7	
Connection type 05	1	2	3	4				
Connection type 08, 09	1	2	3	4			5	
Connection type 10, 11	1	2	3	4	(5)	(6)	5	6
Connection type 12	1	2	3	4	5	6	7	8

Order reference

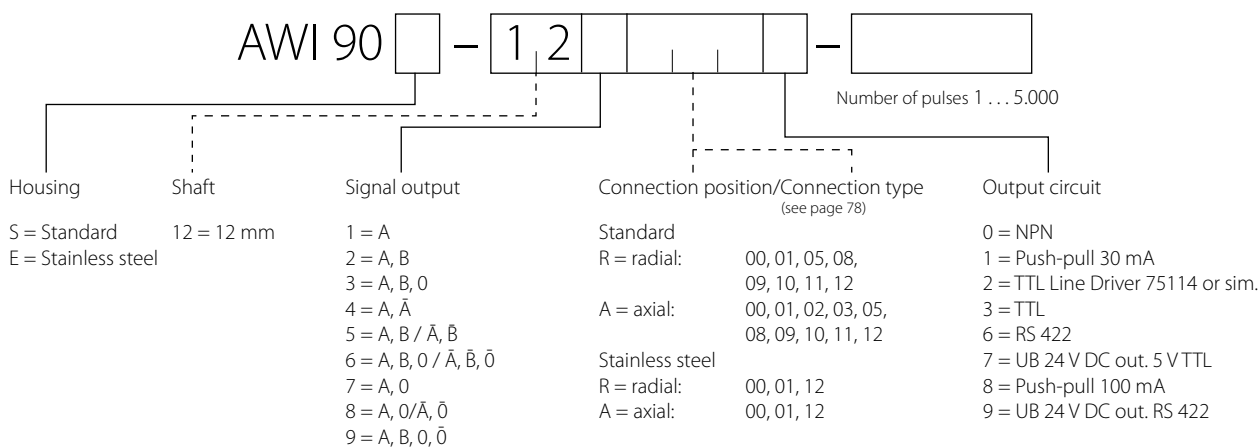

# Series AWI 90 Redundant

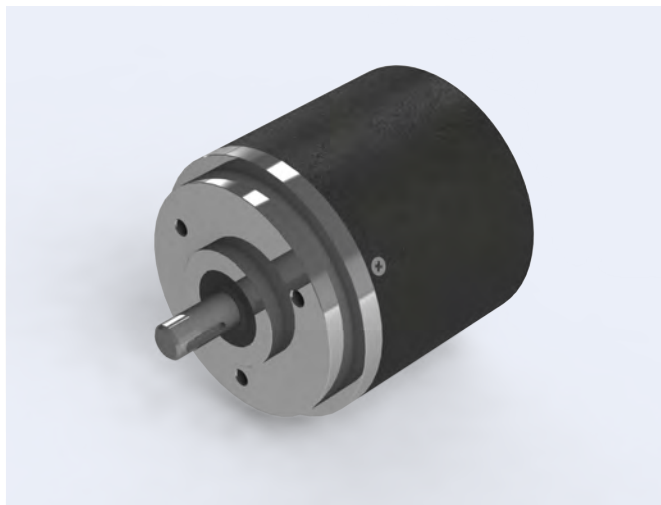

## Series AWI 90 Redundant

- ▶ Incremental rotary-encoder with a solid shaft diameter of 12 mm
- ▶ Housing diameter 90 mm, robust design and high degree of protection
- ▶ Maximum 5.000 pulses / revolution
- ▶ For highest industrial requirements
- ▶ Redundant version (two completely separate, optical and electronic systems in one housing)
- ▶ Also available in stainless steel for aggressive environmental conditions
- ▶ Accessories from page 78

### Electrical specifications

Max. step frequency:	100 kHz
Perm. temperature range:	-30° ... +70° C
Power supply:	10 V ... 30 V DC
Max. current consumption:	80 mA (without load)
Max. output load:	30 mA (per channel)
Residual ripple:	max. ± 5% UB
Power supply:	5 V DC ± 5%
Max. current consumption:	80 mA
	150 mA for Line Driver 75114 or sim.

### Mechanical specifications

Flange:	Aluminium
Housing:	Powder-coated sheet steel
Shaft:	stainless steel
Shaft seal:	oil/salt-water resistant
Bearing:	Deep groove ball bearing
Weight:	approx 1,2 kg
Protection type:	IP 65
Max. speed:	6.000 U/min
Torque:	approx 5 Ncm
Max. shaft load:	axial 30 N/radial 50 N

### Mechanical dimensions

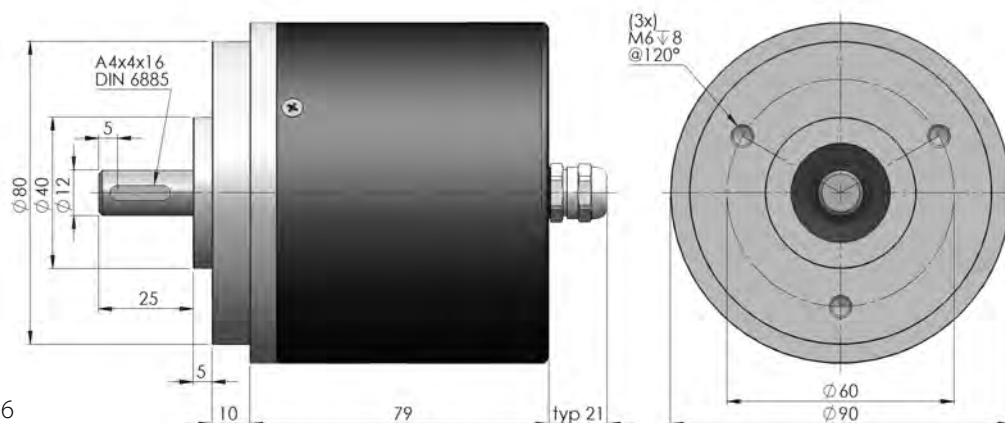

\* Tolerance = h 6

All specification in millimeters

### Output circuits

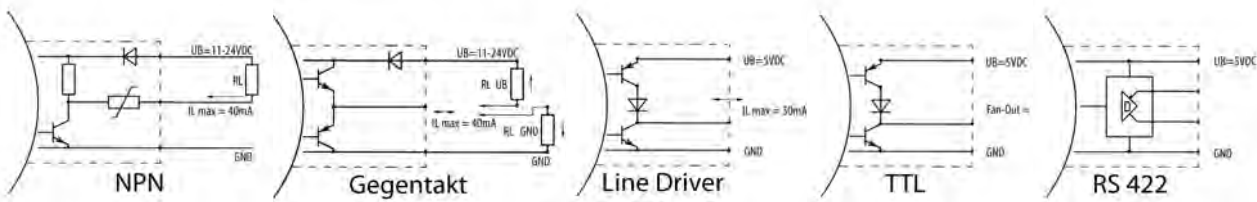

Order ref.: 0

1

2

3

6

### Signal outputs

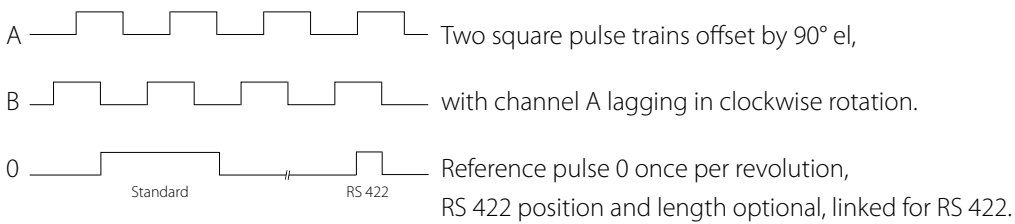

All channels can also be executed inversely.

### Pin configuration

	GND	+ U <sub>B</sub>	A	B	$\bar{A}$	$\bar{B}$	0	$\bar{0}$
Connection type 00 (Colour code according to DIN 47100)	white	brown	green	yellow			gray	
Connection type 00 (Colour code according to DIN 47100)	white	brown	green	yellow	gray	rosa	blue	red
Connection type 01	black	blue	brown	beige			yellow	
Connection type 01	black	blue	brown	beige	yellow	green	pink	purple

### Order reference

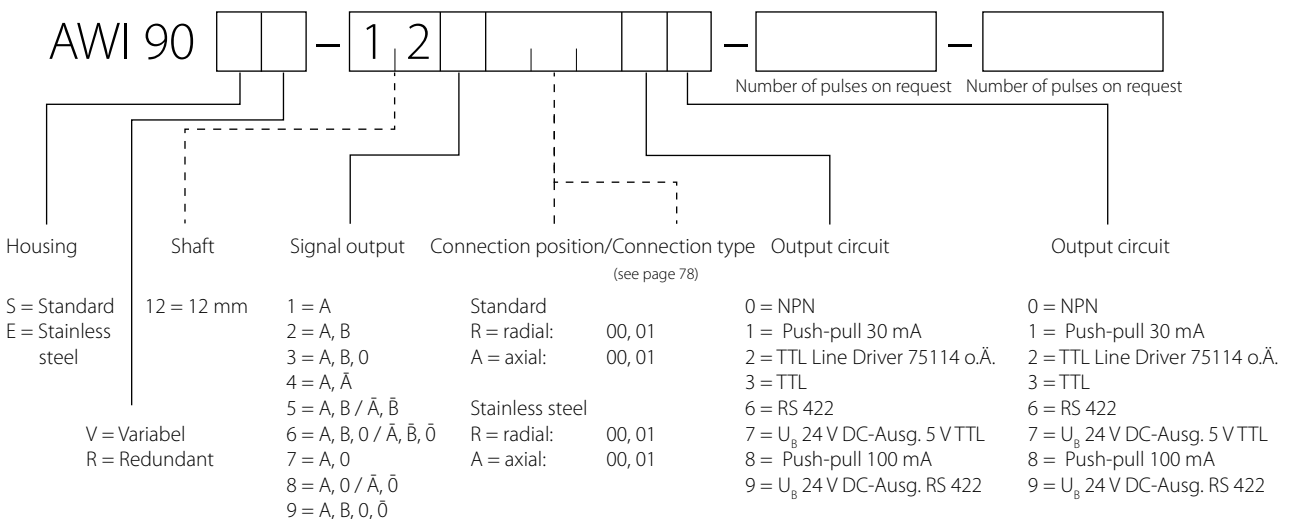

# Series PH 05



## Series PH 05

- ▶ Incremental rotary-encoder with a solid shaft diameter of 12 mm
- ▶ Housing diameter 90 mm, robust design and high degree of protection
- ▶ Maximum 5.000 pulses / revolution
- ▶ For highest industrial requirements
- ▶ Accessories from page 78

### Electrical specifications

max. pulse frequency:	100 kHz
Perm. temperature range:	-30° ... +70° C
Power supply:	10 V ... 30 V DC
Max. current consumption:	80 mA (without load)
Max. output load:	30 mA (per channel)
Residual ripple:	max. $\pm 5\% U_B$
Power supply:	5 V DC $\pm 5\%$
Max. current consumption:	80 mA 150 mA for Line Driver

### Mechanical specifications

Housing:	Powder-coated sheet steel
Flange:	Aluminium
Shaft:	stainless steel
Shaft seal:	Oil/Salt-water resistant
Bearing:	Deep groove ball bearing
Weight:	approx 1,2 kg
Protection type:	IP 65
Max. speed:	6.000 U/min
Torque:	5 Ncm
Max. shaft load:	axial 30 N radial 50 N

### Mechanical dimensions

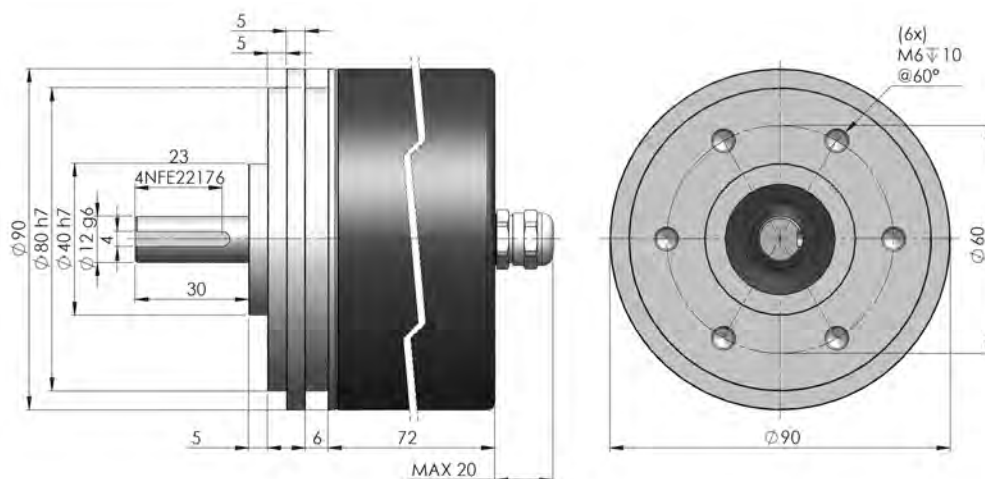

All specification in millimeters

Output circuits

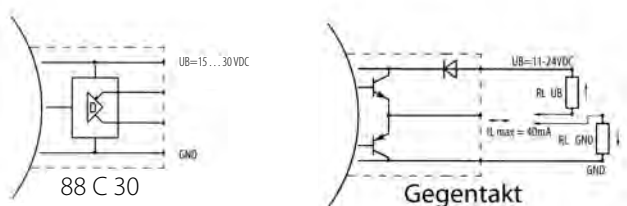

Order ref.: 3

5

Signal outputs

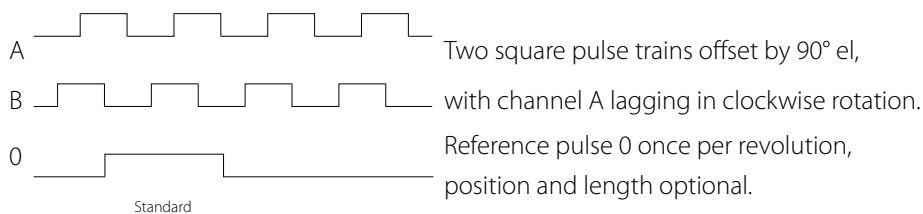

All channels can also be executed inversely.

Pin configuration

Connection	GND	+ U <sub>B</sub>	A	B	0	AN	BN	0N
3R / 3 A	white	brown	green	yellow	blue	gray	pink	red
6R / 6 A	Pin 1	Pin 2	Pin 3	Pin 4	Pin 5	Pin 6	Pin 7	Pin 8

Order reference

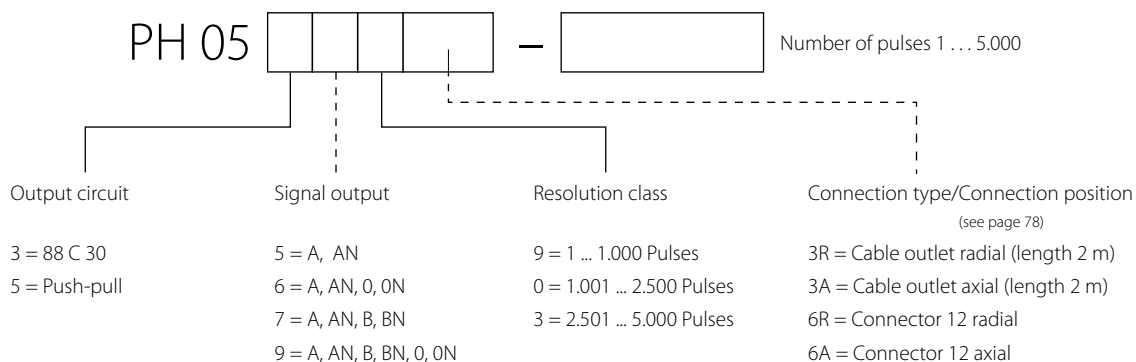

# Series PA 02



## Series PA 02

- ▶ Incremental rotary-encoder with a solid shaft diameter of 12 mm
- ▶ Housing diameter 102 mm, extrem robust design and high degree of protection
- ▶ Maximum 5.000 pulses / revolution
- ▶ For highest industrial requirements
- ▶ Low torque
- ▶ Accessories from page 78

### Electrical specifications

max. pulse frequency:	100 kHz
Perm. temperature range:	-30°... +70° C
Power supply:	10 V... 30 V DC
Max. current consumption:	80 mA (without load)
Max. output load:	30 mA (per channel)
Residual ripple:	max. $\pm 5\% U_b$
Power supply:	5 V DC $\pm 5\%$
Max. current consumption:	80 mA

### Mechanical specifications

Housing:	Zinc die-casting
Shaft:	stainless steel
Bearing:	Deep groove ball bearing
Weight:	approx 1,2 kg
Protection type:	IP 54
Max. speed:	6.000 U/min
Torque:	approx. 3 Ncm
Max. shaft load:	axial 30 N radial 50 N

### Mechanical dimensions

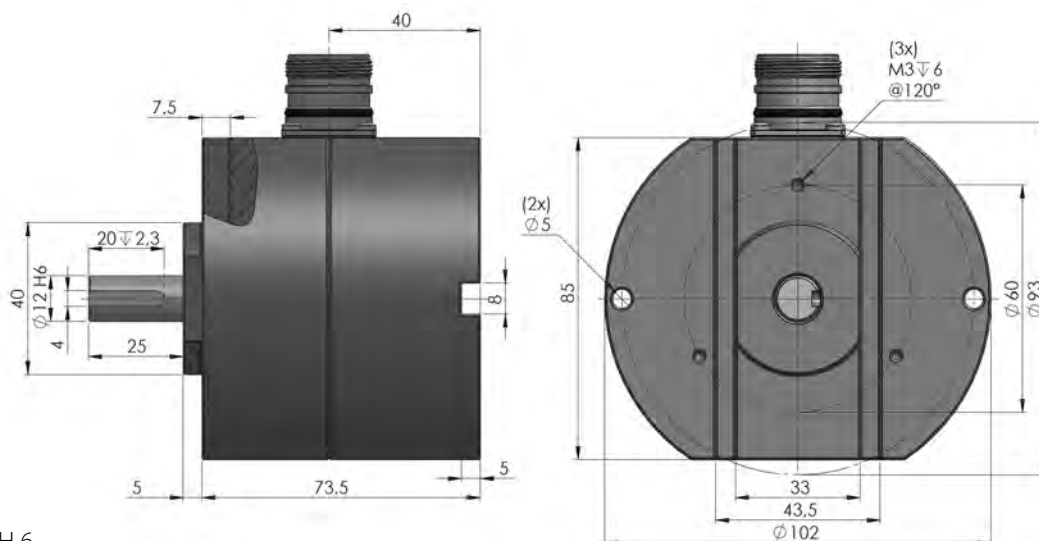

\* Tolerance = H 6

All specification in millimeters

### Output circuits

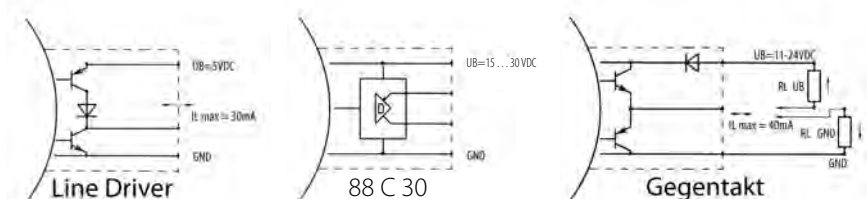

Order ref.: 2

3

5

### Signal outputs

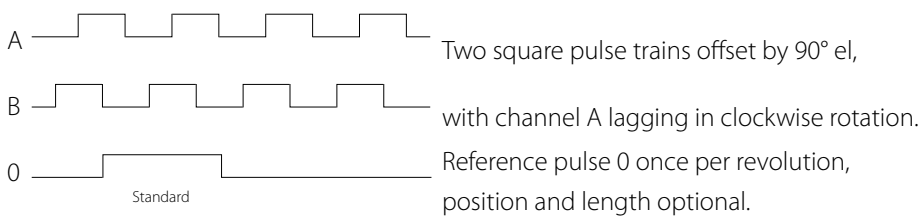

All channels can also be executed inversely.

### Pin configuration

	GND	+ U <sub>B</sub>	A	B	$\bar{A}$	$\bar{B}$	0	$\bar{0}$	$\perp$
Connection type K (01)	black	blue	brown	beige			yellow		yl/gr
Connection type K (01)	black	blue	brown	beige	yellow	green	pink	purple	yl/gr
Connection type 0 (connector 12)	1	2	3	4	5	6	7	8	11

### Order reference

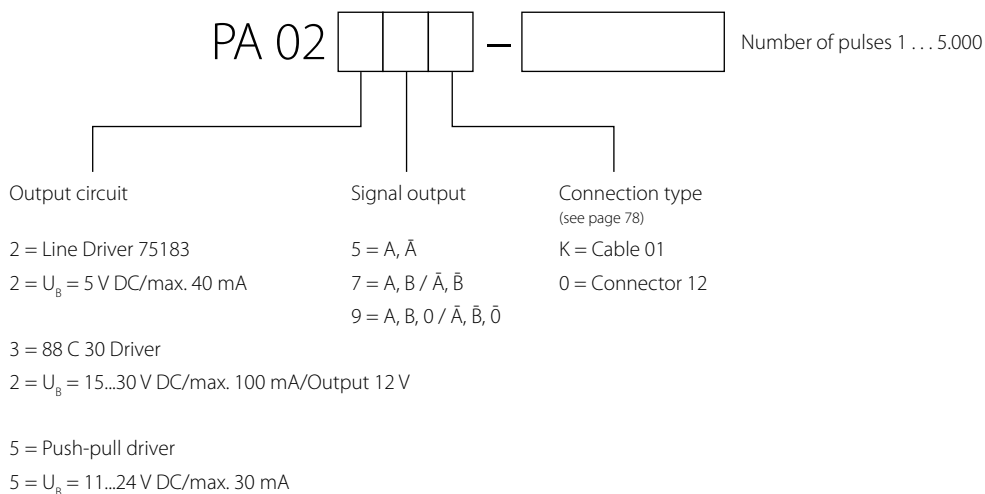

# Series SWI 58



## Series SWI 58

- ▶ Incremental rotary-encoder with a blind hollow shaft diameter of 6-15 mm
- ▶ Housing diameter 58mm, compact design and high degree of protection up to IP67
- ▶ Maximum 5.000 pulses / revolution
- ▶ Compact design for highest mechanical requirements
- ▶ Direct assembly onto existing shafts
- ▶ Accessories from page 78

### Electrical specifications

max. pulse frequency:	100 kHz
Perm. temperature range:	-30° ... +70° C
Power supply:	10 V ... 30 V DC
Max. current consumption:	80 mA (without load)
Max. output load:	30 mA (per channel)
Residual ripple:	max. $\pm 5\% U_B$
Power supply:	5 V DC $\pm 5\%$
Max. current consumption:	80 mA (150 mA for Line Driver 75114 or similar)

### Mechanical specifications

Flange:	Aluminium
Housing:	Zinc die-casting
Shaft:	stainless steel
Bearing:	Deep groove ball bearing
Weight:	approx 0,4 kg
Protection type:	IP 54
Max. speed:	6.000 U/min
Torque:	approx 5 Ncm
Max. shaft load:	axial 100 N/radial 100 N

### Mechanical dimensions

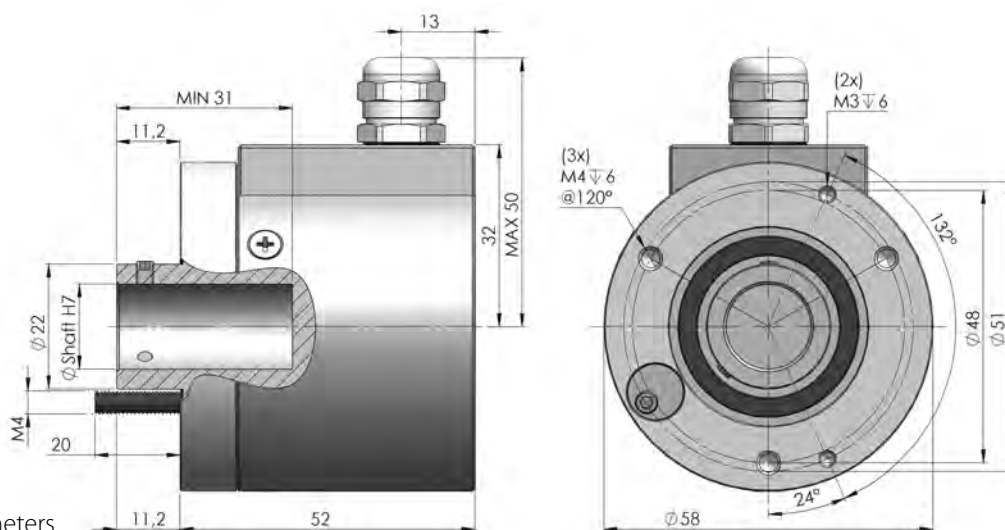

All specification in millimeters



### Output circuits

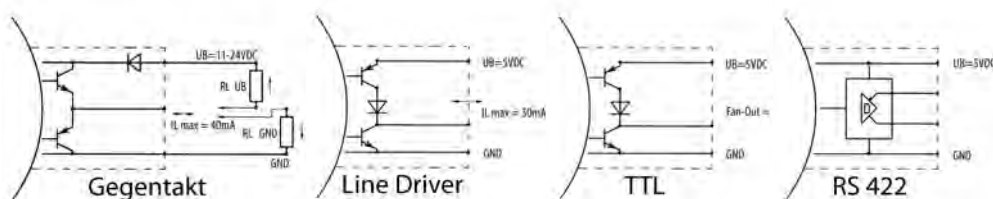

Order ref.: 1                      2                      3                      6

### Signal outputs

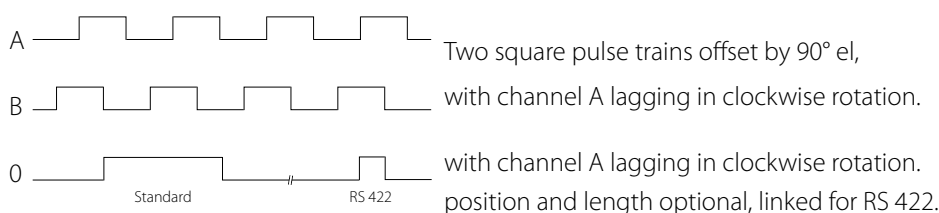

All channels can also be executed inversely.

### Pin configuration

	GND	+ U <sub>B</sub>	A	B	$\bar{A}$	$\bar{B}$	0	$\bar{0}$
Connection type 00 (Colour code according to DIN 47100)	white	brown	green	yellow			gray	
Connection type 00 (Colour code according to DIN 47100)	white	brown	green	yellow	gray	pink	blue	red
Connection type 01	black	blue	brown	beige			yellow	
Connection type 01	black	blue	brown	beige	yellow	green	pink	purple
Connection type 05	1	2	3	4				
Connection type 08, 09	1	2	3	4	(5)		5	
Connection type 10, 11	1	2	3	4	(5)	(6)	5	6
Connection type 12	1	2	3	4	5	6	7	8
Connection type 52	A	B	C	D	E	F	G	

### Order reference

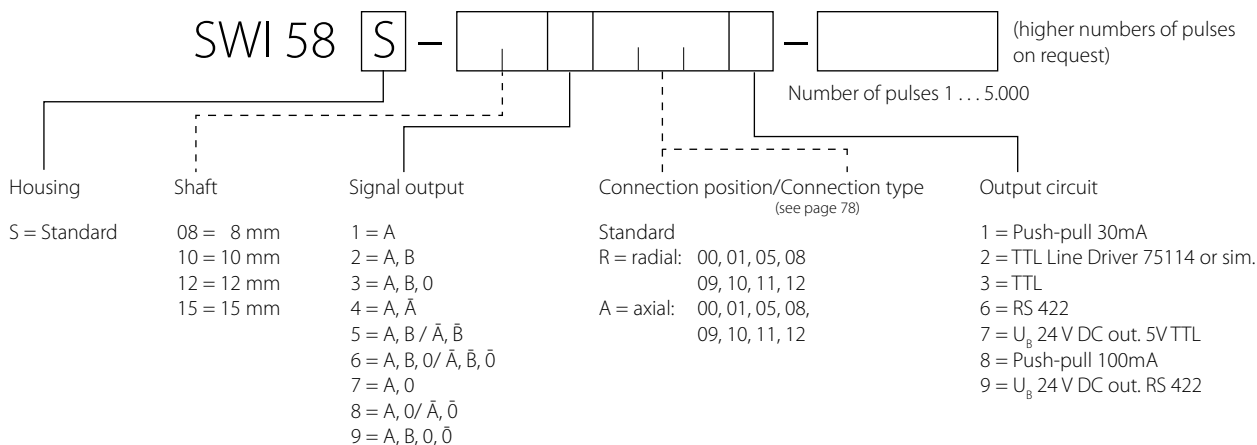

# Series HWI 40



## Series HWI 40

- ▶ Incremental miniature rotary-encoder with a hollow shaft diameter of 6mm
- ▶ Housing diameter 40 mm, small design and standard degree of protection
- ▶ Maximum 1024 pulses / revolution
- ▶ For simple industrial requirements
- ▶ Direct assembly onto existing shafts
- ▶ Accessories from page 78

### Electrical specifications

max. pulse frequency:	25 kHz
Perm. temperature range:	-30° ... +70° C
Power supply:	10 V ... 30 V DC
Max. current consumption:	40 mA (without load)
Max. output load:	30 mA (per channel)
Residual ripple:	max. $\pm 5\% U_B$
Power supply:	5 V DC $\pm 5\%$
Max. current consumption:	40 mA
Max. output load:	30 mA (per channel)

### Mechanical specifications

Flange:	Aluminium
Housing:	Aluminium
Shaft:	stainless steel
Bearing:	Deep groove ball bearing
Weight:	approx 0,1 kg
Protection type:	IP 54
Max. speed:	6.000 U/min
Torque:	approx 1 Ncm

### Mechanical dimensions

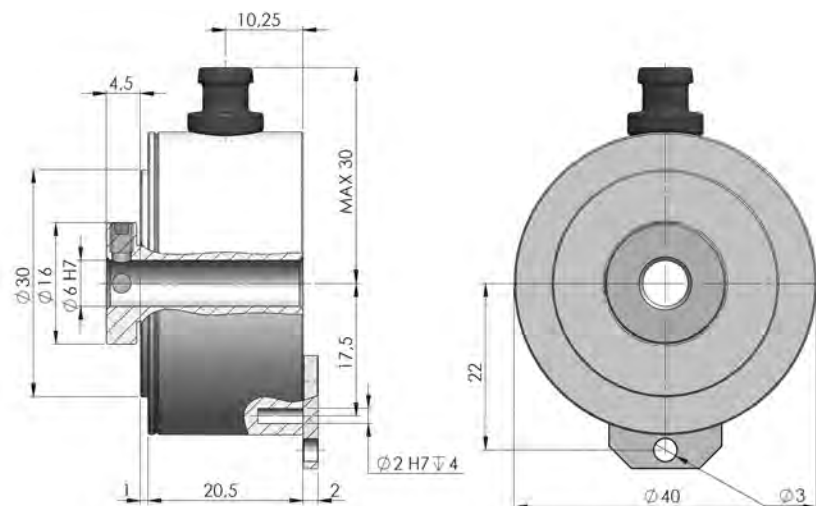

All specification in millimeters

### Output circuits

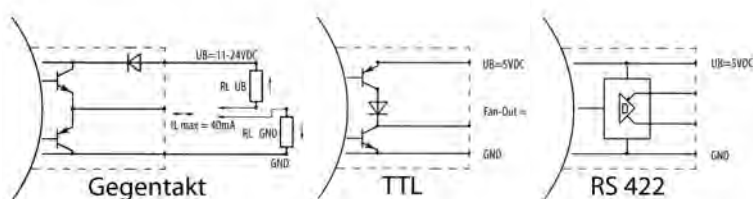

Order ref.: 1

3

6

### Signal outputs

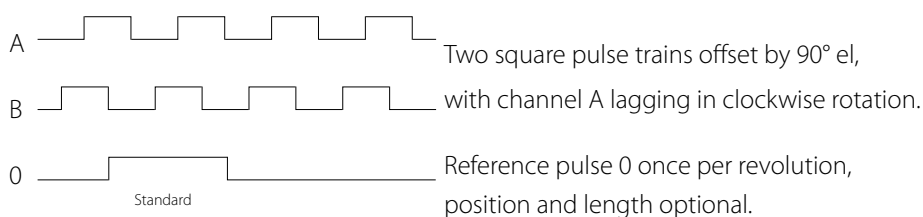

All channels can also be executed inversely.

### Pin configuration

	GND	+ U <sub>B</sub>	A	B	$\bar{A}$	$\bar{B}$	0	$\bar{0}$
Connection type 00 (Colour code according to DIN 47100)	white	brown	green	yellow			gray	
Connection type 00 (Colour code according to DIN 47100)	white	brown	green	yellow	gray	pink	blue	red
Connection type 01	black	blue	brown	beige			yellow	
Connection type 01	black	blue	brown	beige	yellow	green	pink	purple

### Order reference

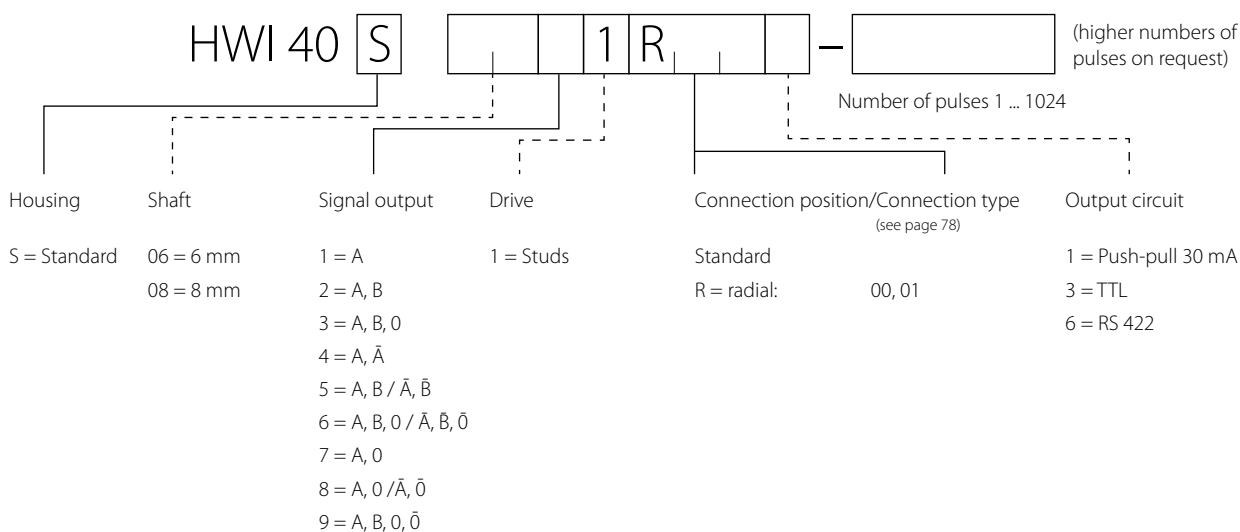

# Series HWI 58

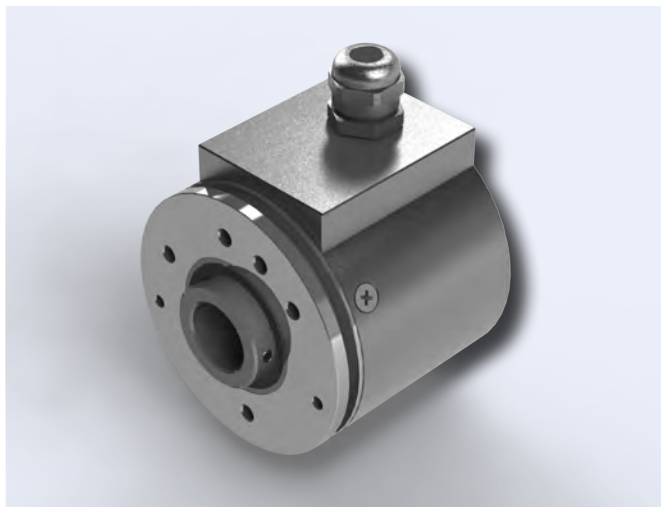

## Series HWI 58

- ▶ Incremental rotary-encoder with a hollow shaft diameter of 6-15 mm
- ▶ Housing diameter 58 mm, compact design and high degree of protection
- ▶ Maximum 5.000 pulses / revolution
- ▶ For highest industrial requirements
- ▶ Direct assembly onto existing shafts
- ▶ Accessories from page 78

### Electrical specifications

max. pulse frequency:	25 kHz
Perm. temperature range:	-30°... +70° C
Power supply:	10 V... 30 V DC
Current consumption:	80 mA (5 V DC)
Max. output load:	30 mA (per channel)
Residual ripple:	max. $\pm 5\% U_B$
Power supply:	5 V DC $\pm 5\%$
Max. current consumption:	80 mA
Max. output load:	30 mA (per channel)

### Mechanical specifications

Flange:	Aluminium
Housing:	Aluminium
Shaft:	stainless steel
Bearing:	Deep groove ball bearing
Weight:	approx 0,4 kg
Protection type:	IP 65
Max. speed:	6.000 U/min
Torque:	approx 3 Ncm
Max. shaft load:	axial 15 N / radial 30 N

### Mechanical dimensions

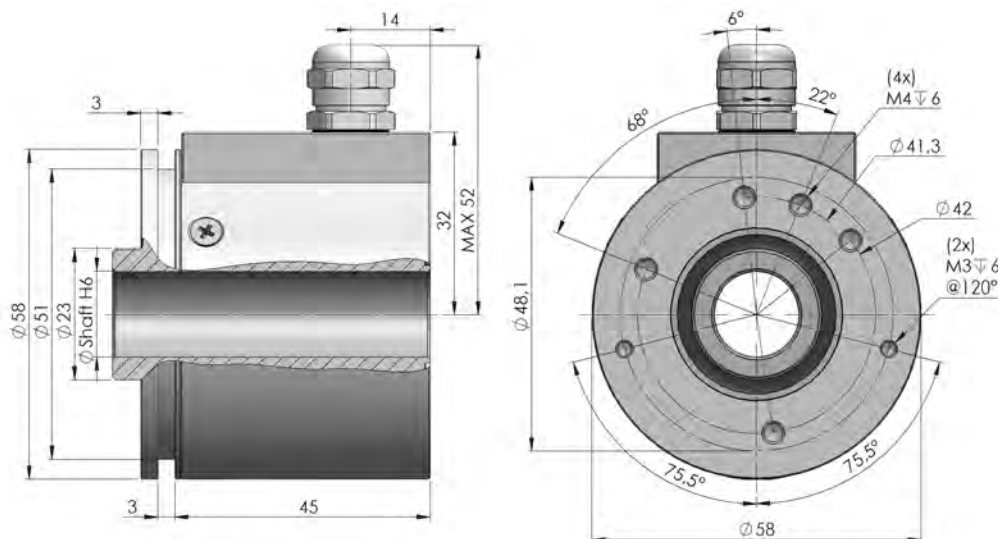

All specification in millimeters



# Series HWI 80



## Series HWI 80

- ▶ Incremental rotary-encoder with a hollow shaft diameter of 6-12 mm
- ▶ Housing diameter 80 mm, small design and high degree of protection
- ▶ Maximum 5.000 pulses / revolution
- ▶ Direct assembly onto existing shafts
- ▶ Also available in stainless steel for aggressive environmental conditions
- ▶ Accessories from page 78

### Electrical specifications

max. pulse frequency:	100 kHz
Perm. temperature range:	-30°... +70° C
Power supply:	10 V... 30 V DC
Max. current consumption:	80 mA (without load)
Max. output load:	30 mA (per channel)
Residual ripple:	max. $\pm 5\% U_B$
Power supply:	5 V DC $\pm 5\%$
Max. current consumption:	80 mA

### Mechanical specifications

Flange:	Aluminium
Housing:	Aluminium
Hollow shaft:	stainless steel
Shaft seal:	oil/salt-water resistant
Bearing:	Deep groove ball bearing
Weight:	approx 0,5 kg
Protection type:	IP 65
Max. speed:	6.000 U/min
Torque:	approx 10 Ncm

### Mechanical dimensions

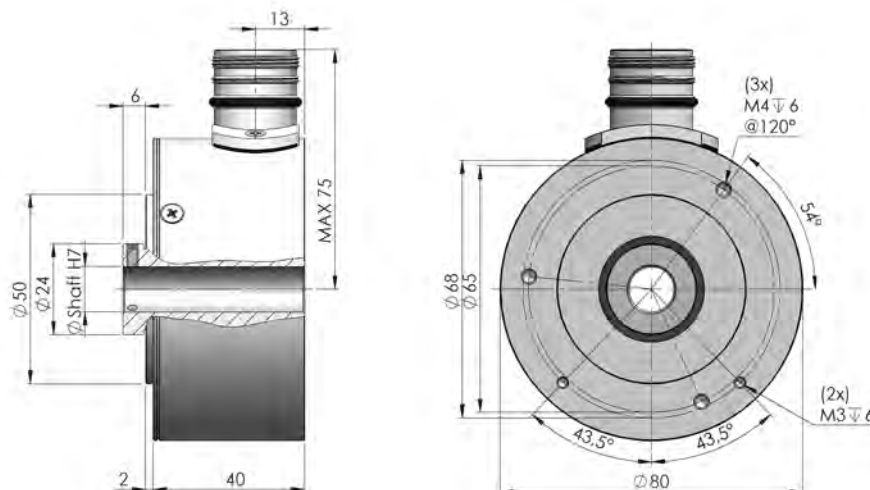

All specification in millimeters

Output circuits

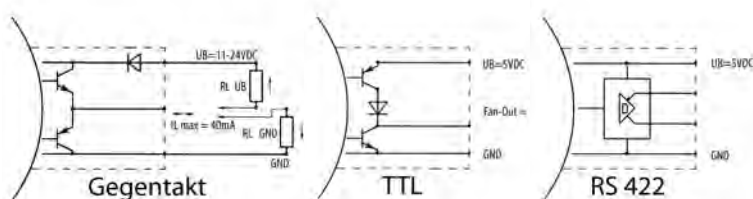

Order ref.: 1

3

6

Signal outputs

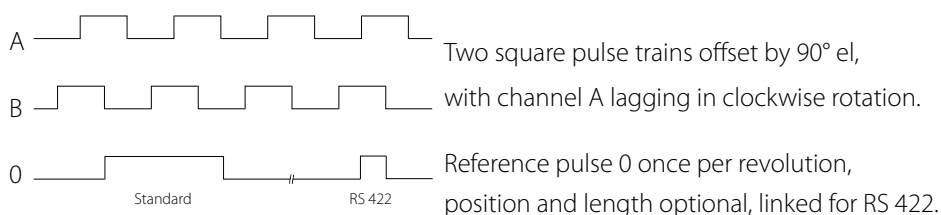

All channels can also be executed inversely.

Pin configuration

	GND	+ U <sub>B</sub>	A	B	$\bar{A}$	$\bar{B}$	0	$\bar{0}$
Connection type 00 (Colour code according to DIN 47100)	white	brown	green	yellow			gray	
Connection type 00 (Colour code according to DIN 47100)	white	brown	green	yellow	gray	pink	blue	red
Connection type 01	black	blue	brown	beige			yellow	
Connection type 01	black	blue	brown	beige	yellow	green	pink	purple
Connection type 07, 08, 09, 10, 11	1	2	3	4	(5)	(6)	5	6
Connection type 12, 54	1	2	3	4	5	6	7	8

Order reference

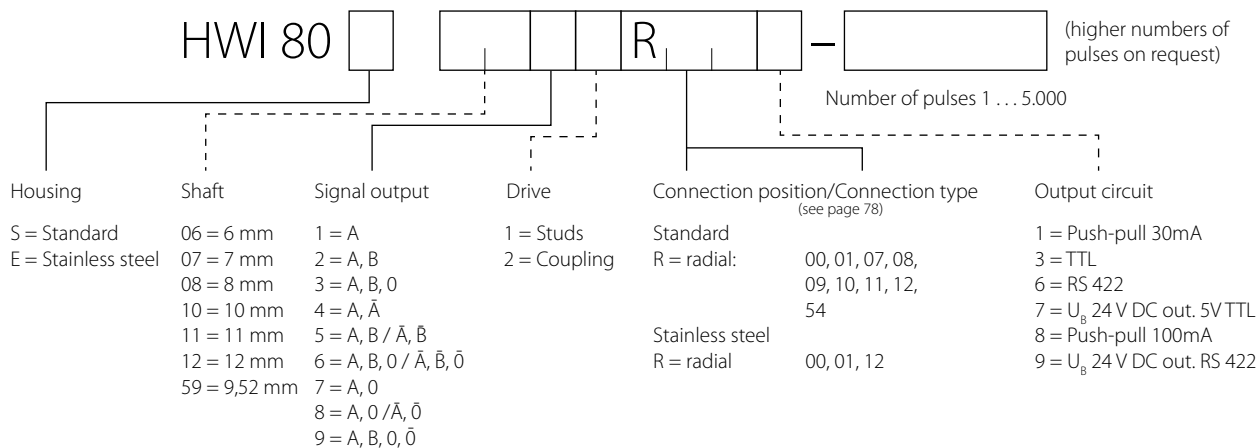

# Series HWI 103

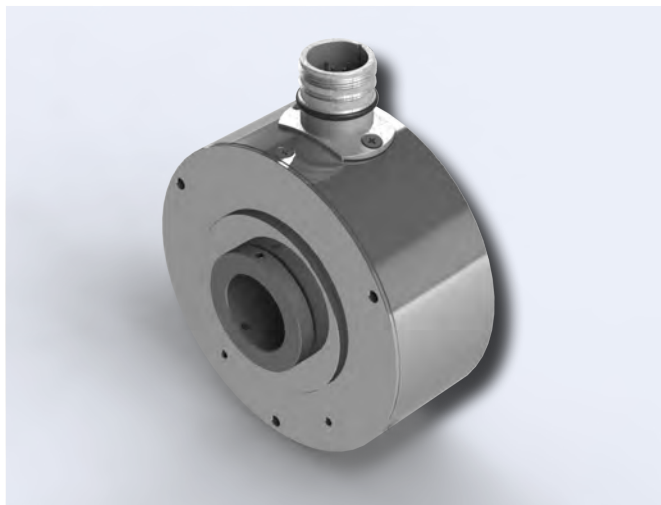

## Series HWI 103

- ▶ Incremental rotary-encoder with a hollow shaft diameter of 10-25,4 mm
- ▶ Housing diameter 103 mm, small design and high degree of protection
- ▶ Maximum 5.000 pulses / revolution
- ▶ Direct assembly onto existing shafts
- ▶ Also available in stainless steel for aggressive environmental conditions
- ▶ Accessories from page 78

### Electrical specifications

max. pulse frequency:	100 kHz
Perm. temperature range:	-30°... +70° C
Power supply:	10 V... 30 V DC
Max. current consumption:	80 mA (without load)
Max. output load:	30 mA (per channel)
Residual ripple:	max. $\pm 5\% U_B$
Power supply:	5 V DC $\pm 5\%$
Max. current consumption:	80 mA

### Mechanical specifications

Flange:	Aluminium
Housing:	Aluminium
Hollow shaft:	stainless steel
Shaft seal:	oil/salt-water resistant
Bearing:	Deep groove ball bearing
Weight:	approx 0,8 kg
Protection type:	IP 65
Max. speed:	6.000 U/min
Torque:	approx 15 Ncm at 25° C approx 50 Ncm at 20° C

### Mechanical dimensions

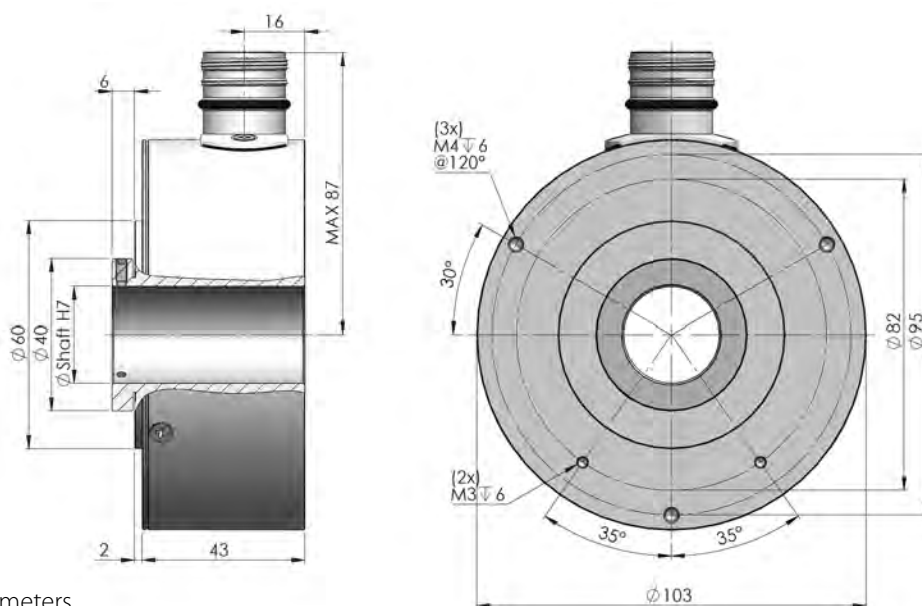

All specification in millimeters



### Output circuits

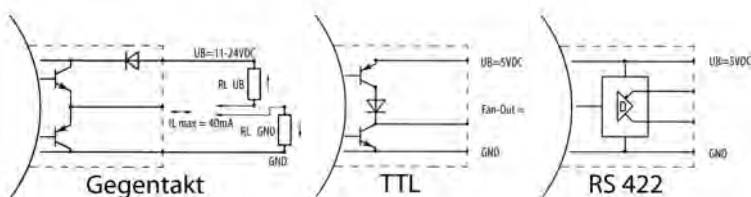

Order ref.: 1

3

6

### Signal outputs

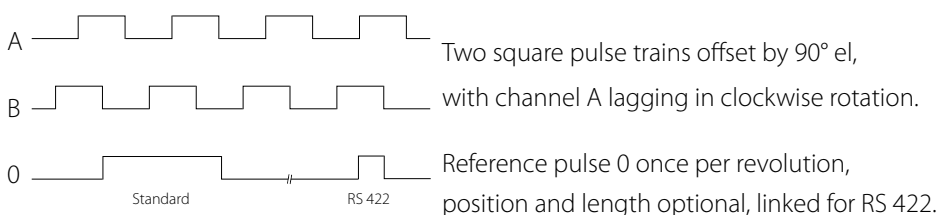

All channels can also be executed inversely.

### Pin configuration

	GND	+ U <sub>B</sub>	A	B	$\bar{A}$	$\bar{B}$	0	$\bar{0}$
Connection type 00 (Colour code according to DIN 47100)	white	brown	green	yellow			gray	
Connection type 00 (Colour code according to DIN 47100)	white	brown	green	yellow	gray	pink	blue	red
Connection type 01	black	blue	brown	beige			yellow	
Connection type 01	black	blue	brown	beige	yellow	green	pink	purple
Connection type 07, 08, 09, 10, 11	1	2	3	4	(5)	(6)	5	6
Connection type 12, 54	1	2	3	4	5	6	7	8

### Order reference

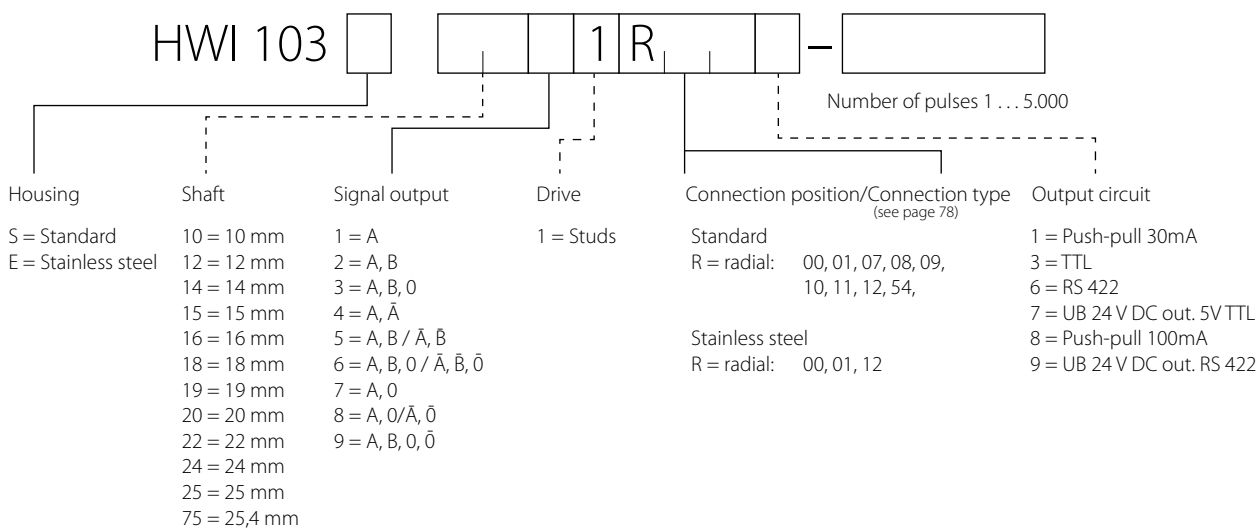

# Series MIG Nova+



## Series MIG Nova+

- ▶ Compact design; 7 - 15 mm thick
- ▶ Standard flanges sizes from 80 to 450 mm
- ▶ Compatible with any IEC standard motor, size 56 to 225
- ▶ Space-saving and protective assembly between motor and gearbox; protection class IP67
- ▶ Also applicable to existing drives
- ▶ Epoxy resin sealed encoder electronics
- ▶ Unbreakable vulcanized magnet ring
- ▶ 1 - 2048 impulses (A 90°B) per revolution
- ▶ Contactless signal measurement
- ▶ Output signal A 90° B and inverted
- ▶ Up to 6000 rpm.
- ▶ Line driver output, 10 - 24 VDC and TTL 5 VDC
- ▶ Flange material in aluminum and available in stainless steel
- ▶ Special construction and material on request
- ▶ Standard with 2 m, screened cable.  
Different lengths and plug connection on request.

### Electrical specifications

Connecting voltage $U_b$ :	5 to 24 VDC
Max. impulse frequency:	$\leq 100$ kHz
Output signals:	Square wave-impulses, A 90° B and A 90° B inverted
Impulses:	1 ... 512, 1.024, 2.048
Signal level:	$U_{high} \geq U_b - 0,7$ V at $I_{last} \leq 10$ mA $U_{low} \leq -0,7$ V at $I_{last} \leq 10$ mA
Output capacities:	$\leq 30$ mA at $U_b = 10$ V DC or $\leq 20$ mA at $U_b = 24$ V DC
Output switching:	Line-Driver (Push-Pull)
External evaluation:	NPN, PNP, RS422
Reversepolarity protected:	Yes
Short circuit protection at the output:	Yes
Motor shaft tolerance:	0,2 mm axial - 0,05 mm radial

### Mechanical specifications

Max. speed:	6.000 min <sup>-1</sup> (1.024 impulses) 3.000 min <sup>-1</sup> (2.048 impulses)
Temperature range:	-30° C to +80° C
Flange/hub material:	Aluminium, stainless steel (additional price) / Magnet vulcanized
Connection cable:	PUR-sheath 6 x 0,14 screened (A+B, A+B inv.) Standard 2 m or on request
Cable length:	Depending on the impulses and RPM max. 100 m at 5 V DC max. 20 m at 24 V DC max. 50 m at 24 V DC and impulse frequency max. 50 kHz
Protection type:	Standard IP55, depending on the sealant used between motor and machine flange IP67. Please take note in the operating manual.

Mechanical Dimensions

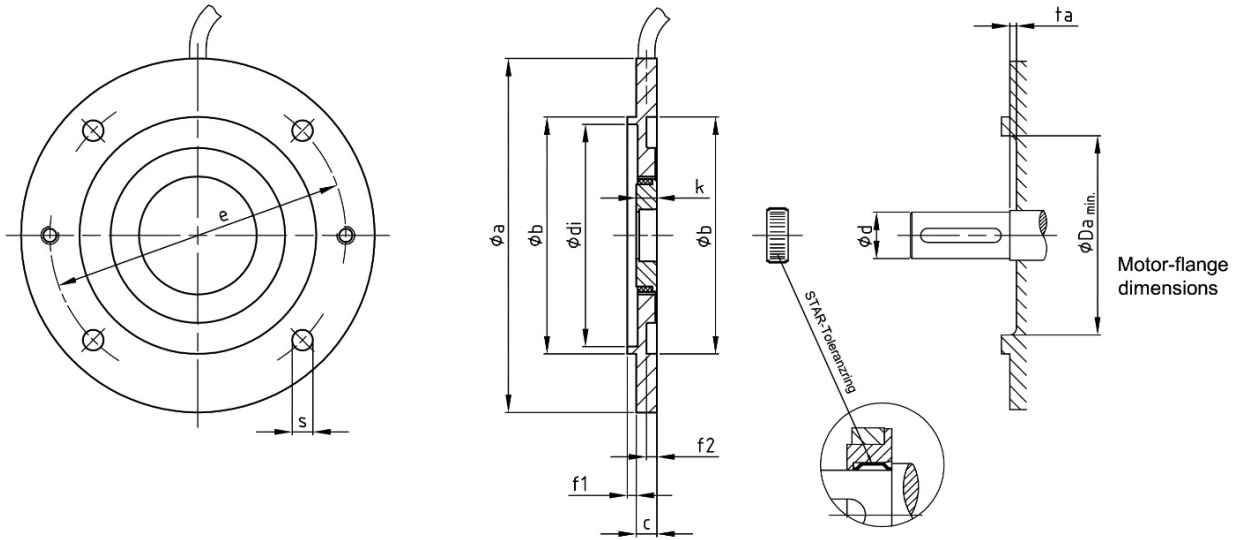

MIG Nova+ Dimensions									Standard motor sizes (BG) according to IEC				
$\phi_a$	$\phi_b$	c	$\phi_{di}$	$\phi_e$	f1	f2	k	s	BG	Fl.	$\phi d \times l$	$t_a$	$\phi Da$
80	50	7	44	65	2,5	3	7	5,8	56	FT 65	$\phi 9 \times 20$	2	43
90	60	7	54	75	2,5	3	7	5,8	63	FT 75	$\phi 11 \times 23$	2	43
105	70	7	64	85	2,5	3	7	7	56	FT 85	$\phi 9 \times 20$	2	60
									71	FT 85	$\phi 14 \times 30$	2	60
120	80	7	74	100	3	3,5	7	7	56	FT 100	$\phi 9 \times 20$	2	60
									63	FT 100	$\phi 11 \times 23$	2	60
									80	FT 100	$\phi 19 \times 40$	2	60
140	95	7	85	115	3,5	4	7	9	63	FT 115	$\phi 11 \times 23$	2	60
		9	85	115	3,5	4	9	9	90	FT 115	$\phi 24 \times 50$	3	60
160	110	7	100	130	3,5	4	7	9	71	FT 130	$\phi 14 \times 30$	2	60
		80	FT 130	$\phi 19 \times 40$	2	60							
		9	100	130	3,5	4	9	9	90	FT 130	$\phi 24 \times 50$	3	60
		100	FT 130	$\phi 28 \times 60$	3	105							
200	130	9	120	165	3,5	4	9	11	80	FT 165	$\phi 19 \times 40$	2	60
									90	FT 165	$\phi 24 \times 50$	3	60
		12	120	165	3,5	4	12	11	100	FT 165	$\phi 28 \times 60$	3	60
									112	FT 165	$\phi 28 \times 60$	3	105
250	180	12	170	215	4	5	12	13,5	132	FT 165	$\phi 38 \times 80$	3	105
									100	FT 215	$\phi 28 \times 60$	3	60
									112	FT 215	$\phi 28 \times 60$	3	60
300	230	12	218	265	4	5	12	13,5	132	FT 215	$\phi 38 \times 80$	3	105
350	250	12	238	300	5	6	12	17	160	FT 300	$\phi 42 \times 110$	3	105
									180	FT 300	$\phi 48 \times 110$	3	105
400	300	15	290	350	5	6	15	17,5	200	FT 350	$\phi 55 \times 110$	3	105
450	350	15	340	400	5	6	15	17,5	225	FF 400	$\phi 55 \times 110$	3	105
											$\phi 60 \times 140$		

# Series MIG Nova+

## Series MIG Nova+

The very compact **MIG Nova+** encoder flange is available with pulses from 1 to 2048 per revolution and has a revolutionary vulcanized magnet ring. The flange has standard dimensions and therefore fits on every IEC motor. With a minimum thickness of 7 mm, your drive is only a fraction longer and the epoxy resin sealed encoder electronics is completely protected from external influences. Extremely suitable for the „wet applications“ such as the food, dairy and fish processing industry.



**IEC flange design**

e.g. Flange motor

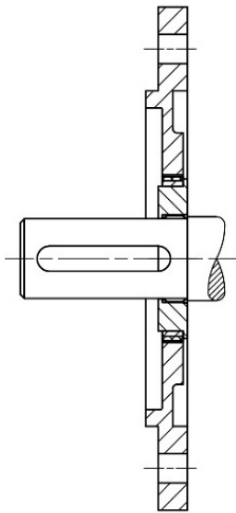

Motor B5 and B 14

**Cover design\***

e.g. conventional motor

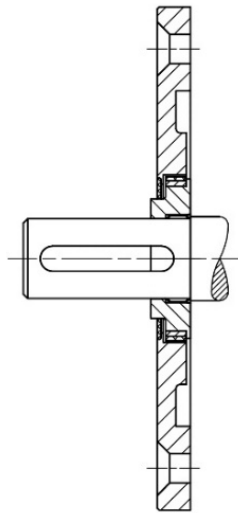

Motor B3/B5 and B3/B4

\*Cover width by flange width „C“ on page 35  
7 mm = 9,3 mm / 9 mm = 11 mm / 12 mm = 15 mm

**Design with plug-in connection 4 pin plug**

not for TTL design

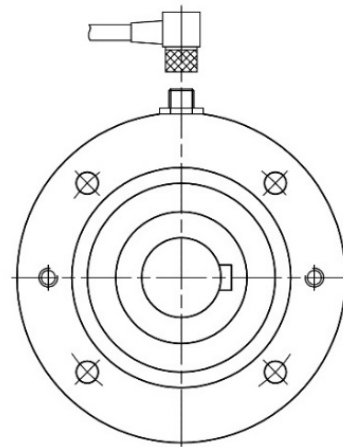

View of motor shaft  
(cable connection left)

**Terminals**

Terminal	Ub	0V	A	B	A'	B'
Cable	brown	white	yellow	green	pink	gray

Attention: Please isolate not required connection lacings and protect them from short-circuits!

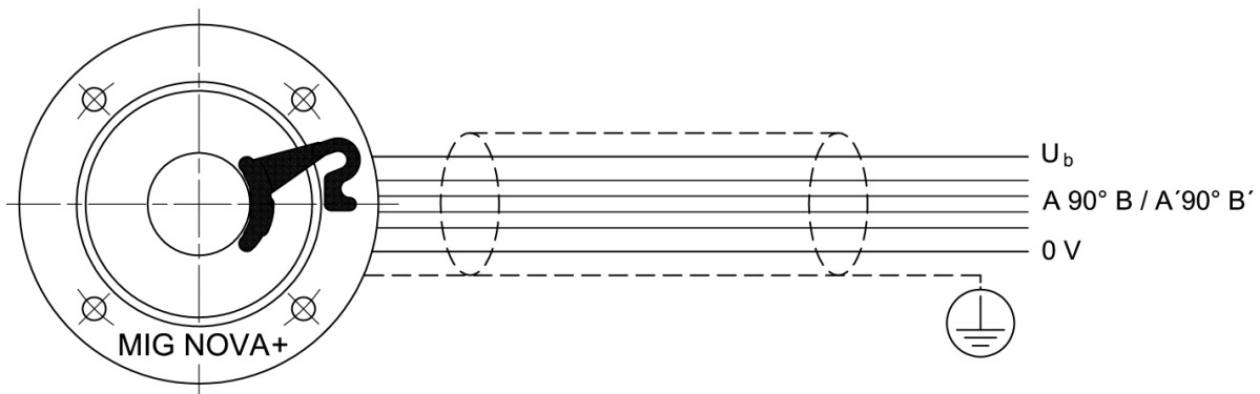

# Series AWI 70 Ex & HWI 70 Ex



## Series AWI 70 Ex & HWI 70 Ex

- ▶ Incremental Ex-rotary-encoder with 10, 12 or 14 mm solid- or blind hollow shaft
- ▶ Housing diameter 70 mm for design type "Pressurised encapsulation" and high degree of protection
- ▶ With Ex d IIC T6 (PTB 09 ATEX 1106 X)
- ▶ Maximum 5.000 pulses / revolution
- ▶ Short-circuit-proof outputs
- ▶ Overvoltage and reverse polarity protection on the operating voltage input (at  $U_b = 10-30\text{ V DC}$ )
- ▶ Accessories from page 78

### Mechanical specifications

Speed:	max. 6.000 U/min.*	Working temperature range:	-40° C ... + 60° C
Moment of inertia of the rotor:	approx $4 \times 10^{-6} \text{ kgm}^2$	Shaft:	Stainless steel
perm. shaft load radial:	80 N (at shaft end) <sup>1</sup>	Shock resistance according to	
perm. shaft load axial:	40 N	DIN EN 600068-2-27:	2.500+ m/s <sup>2</sup> , 6 ms
Starting torque (25° C):	< 0,05 Nm	Vibration resistance according to	
Weight:	approx 1,5 kg	DIN EN 600068-2-6:	100 m/s <sup>2</sup> , 55 Hz ... 2.000 Hz
Protection class according to EN 60 529:	IP 67		* in continuous operation max. 1500 U/min <sup>1</sup> for shaft design

### Electrical specifications

Output circuit	RS 422 (TTL compatible)	Push-pull circuit
Supply voltage	5 V DC (+/- 5%)	10 - 30 VDC
Current consumption without inversions (without load)	type 40 mA / max. 90 mA	type 50 mA / max. 100 mA
max. perm. load/channel	+/- 20mA	+/- 20 mA
max. pulse frequency	300 Hz	300 Hz
Signal level high	min. 2,5 V	min. +V -1,0 V
Signal level low	max. 0,5 V	max. 0,5 V
Rise time tr	max. 200 ns	max. 1 μs
Fall time tr	max. 200 ns	max. 1 μs
Short-circuit proof <sup>1)</sup>	yes <sup>2)</sup>	yes
Reverse polarity protection on UB	no	yes

<sup>1)</sup> With correctly applied supply voltage  $U_b$

<sup>2)</sup> Only one channel at the same time: with  $U_b = 5\text{ V}$  short circuit to channel and 0 V and + UB is permissible  
with  $U_b = 10 - 30\text{ V}$  short circuit to channel and 0 V is permissible

## Mechanical dimensions

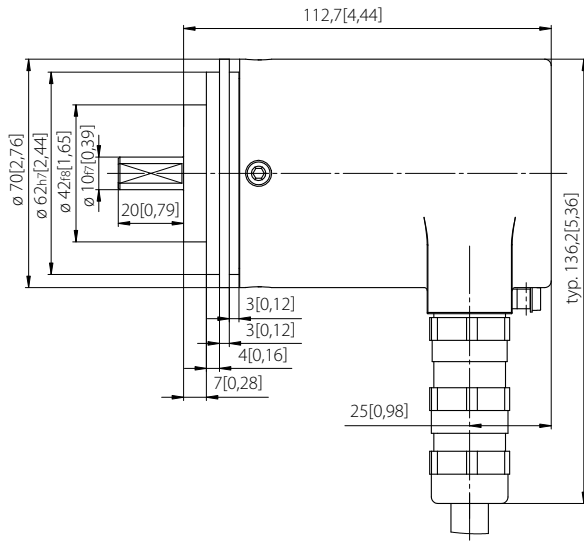
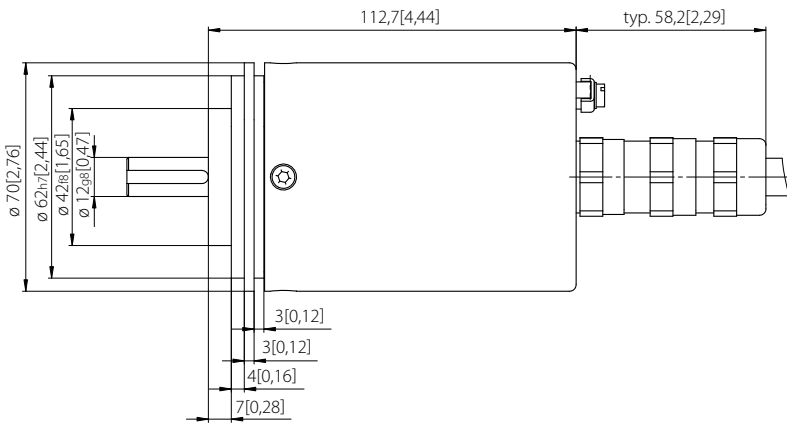





**Installation instructions**

Flange and shaft of encoder and drive may not be rigidly coupled at the same time!

**Please observe**

All current standards for installing electrical systems in potentially explosive atmospheres must be observed during installation! Manipulations of the encoder (opening, mechanical processing) will lead to the loss of ex approval and guarantees! The installer assumes the consequential liability!

**Pulse image**

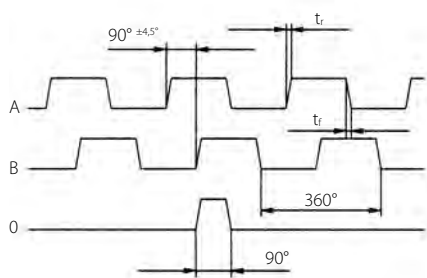

Direction of rotation (relative to pulse image)  
Shaft rotating clockwise, facing the shaft

Recommended encoders according to RS 422 - specification  
e.g. DS 3486 or AM 26LS32

All channels can also be executed inversely.

**Numbers of pulses available at short notice:**

1, 5, 10, 12, 250, 256, 360, 400, 500, 512, 600, 800, 1.000, 1.024, 1.200, 2.000, 2.048, 2.500, 3.000, 3.600, 4.096, 5.000  
Other numbers of pulses upon request

**Pin configuration**

Cable	Sig.	0V	0V Sensor	+U <sub>B</sub>	+U <sub>B</sub> Sensor	A	$\bar{A}$	B	$\bar{B}$	0	$\bar{0}$
01	Colour	white	gray/pink	brown	red/brown	green	yellow	gray	pink	blue	red
	Control line	1	9	2	10	3	4	5	6	7	8

SG = Shield located on housing of the cable gland. The sensor cables are connected internally with the power supply. Unused outputs must be insulated prior to commissioning.

**Order reference**

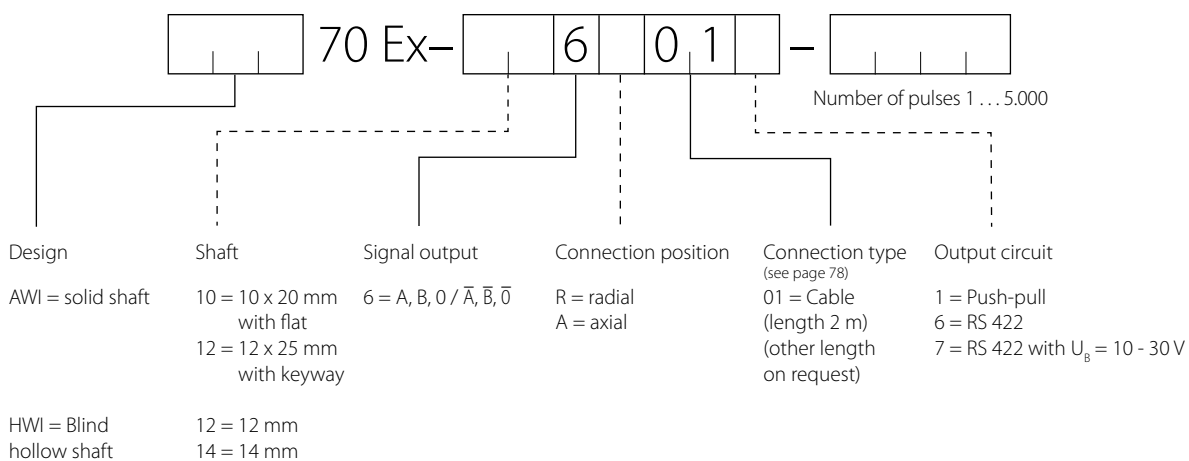

# Absolute Rotary Encoders

## General descriptions

Absolute rotary encoders are optoelectronic sensors collecting and encoding angles or distances. A digitally coded value is assigned to each measuring step defined by the division on a measuring body (code disk). This absolute measured value can be read as often as desired, is reproducible and not corrupted by power failures.

The one-step gray code is basically used with the code disk (measuring body). The one-step coding has the advantage of avoiding intermediate values while measuring step changes.

## Output codes

### Gray code

This is a one-step format code whose individual positions have no significance. Only 1-bit changes during measure value change thus avoiding intermediate values that can occur in multi-step output codes. The number of positions to represent a position value corresponds to those of the binary codes.

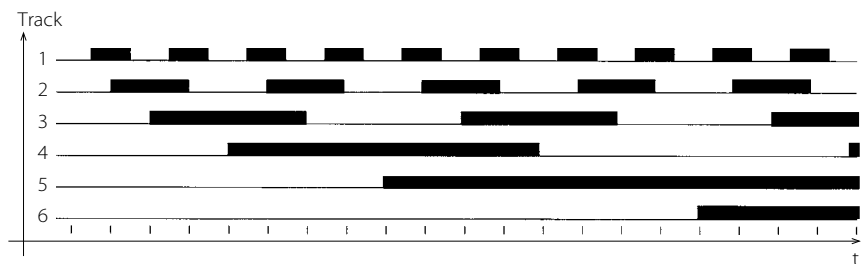

### Gray excess codes

The one-step coding of the gray code applies to resolutions that can be represented as potency (x) to the base 2 ( $2^x$ ). A central part is taken from the gray code for other resolutions, which guarantees that the one-step coding is maintained. This output code is known as gray express code.

It should be observed that the representation range no longer begins at "0", but shifts by a certain value (e.g. resolution 360 steps/revolution corresponds to 76 - 435 range).

### Binary code

With this assessable output code, a precise valence with the potency (x) to the base 2 ( $2^x$ ) is assigned to each position value.

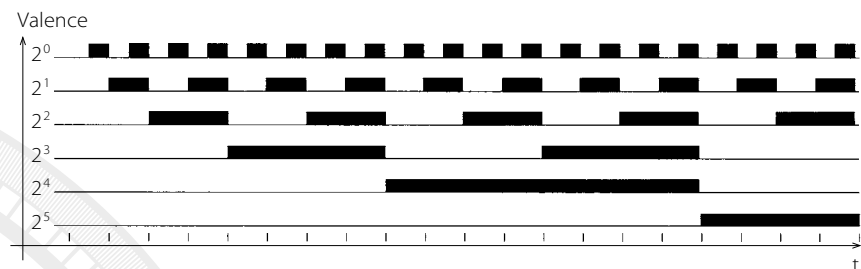

### BCD code (8-4-2-1 code)

This is an assessable decades code. Each decade of the decimal system is represented by a 4-bit binary number. The 6 redundant combinations (10-15) of the binary code are not used. They are also referred to as pseudo-tetradecades.

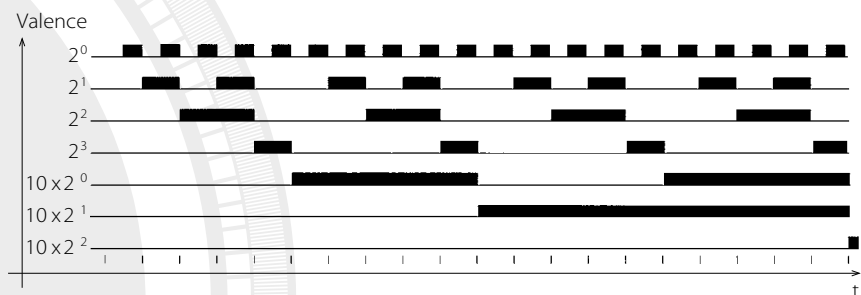

## Input

**Counting direction switchover** - The output of the position value facing the shaft clockwise is ascending with absolute rotary encoders. The counting direction is reversible via this output.

**Latch** - The output data of the absolute rotary encoder can be "frozen" via this input. This enables an error-free takeover of the position values to a control.

## Calculation of permissible speed

Depending on the max. step frequency of 10 kHz, the permissible speed is roughly calculated according to the following Formula:

$$n \left( \frac{u}{\min} = \frac{f_{\max} \text{ (Hz)}}{\text{Resolutions}} \right) \times 60$$

Attention: This calculation does not take into account the influence of the cable length; in addition, the permissible mechanical speed should be observed!!

## Output circuits

0 Darlington Driver  
ULN 2003 o.ä.  
max. 40 mA per channel  
short-circuit-proof

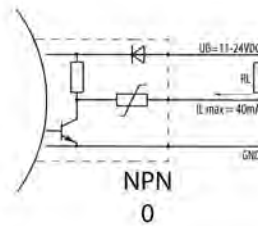

1 Push-pull  
max. ±10 mA

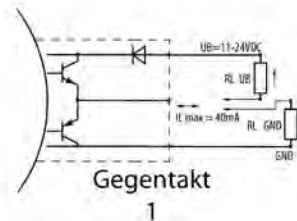

3 TTL  
max. 1,6 mA per channel  
(1 TTL-Load)

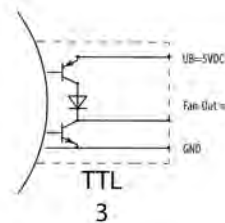

5 High Current Source  
Driver UDN 2982 or.sim

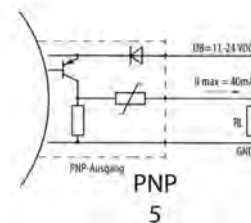

6,7 serial output SSI

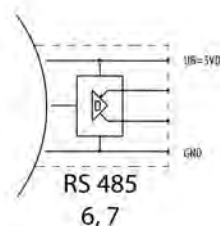

# Absolute Rotary Encoders

## Synchronous serial transmission (SSI) for absolute rotary encoders

Absolute rotary encoders are, in many cases, subject to severe mechanical stresses, electrical and magnetic fields contaminating the operating site. Special constructive measures are, therefore, required to combat dirt, dust and liquids in the industrial environment. Our absolute rotary encoders have a mechanically robust design according to the latest technologies, and the electronics are designed as compact as possible.

The main focus in the interference resistance applies to the data transmission from the rotary encoder to the control. The measuring data of the rotary encoder must be read error-free from the control. Under no circumstances should undefined data be transmitted, e.g. at the changeover point. The concept described here for synchronous serial data transfer for absolute rotary encoders differs essentially from the parallel and asynchronous serial transmission types by:

- fewer electronic components
- fewer cables for data transfer
- the same interface hardware, regardless of the resolution (word lengths) of the absolute rotary encoder
- galvanic isolation of the rotary encoder of the control by octocoupler
- line breakage monitoring by constant current
- data transfer rates up to 1.5 Mbit/s (depending on the cable length)
- Ring register operation possible

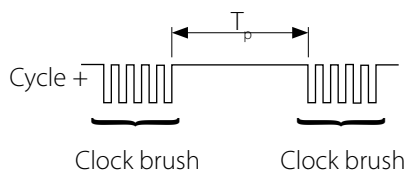

## Transfer procedure

For correct data transfer, it is necessary to apply a defined number of pulses (clock brushes) at the input of the absolute rotary encoder. A  $T_p$  pause must be observed thereupon. As long as no clock signal is applied to the rotary encoder, the encoder's internal parallel/serial shift register is switched to parallel. The data are free-running and correspond respectively to the position of the rotary encoder shaft. As soon as a clock brush is reapplied, the current angle information is stored.

The first change of the clock signal from high to low actuates the rotary encoder's internal retriggerable monoflop, whose  $t_m$  monoflop timeout must be greater than the period duration  $T$  of the clock signal.

The output of the monoflop controls the parallel/serial register via the P/S (parallel/serial) port.

Block diagram of an absolute rotary encoder

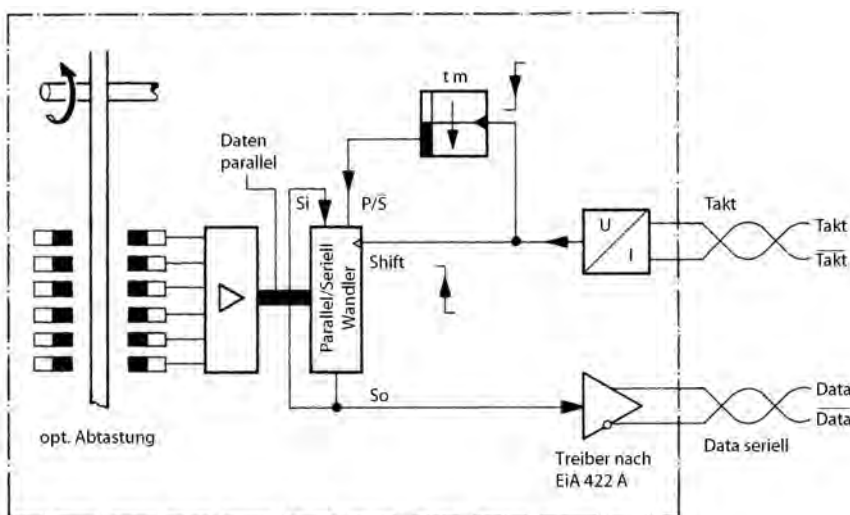

## Synchronous serial transfer

The number of clocks required for data transfer is independent of the resolution of the absolute rotary encoder. The cycle can be interrupted at any point, or continued for multiple queries in the ring register operation.

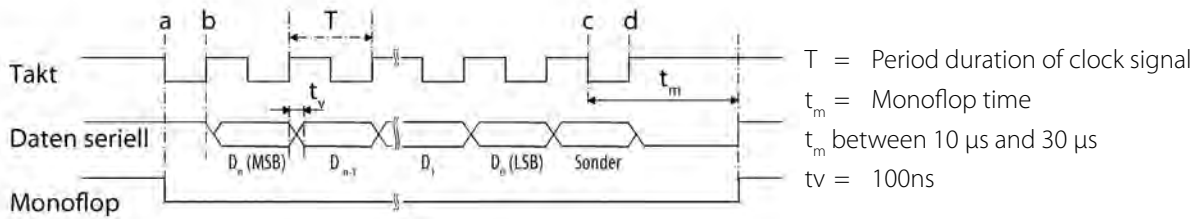

The first change of the clock signal from low to high b applies the most significant bit (MSB) of the angle information to the serial data output of the rotary encoder.

Each succeeding rising edge shifts the next least-significant bit to the data output. After transfer of the next least-significant bit (LSB), the alarm bit or other special bits are transferred, depending on the configuration. Then the data line switches from low c until the  $t_m$  time has elapsed.

Another data transfer can only be started when the data line is switched to high d again. If the clock change is not interrupted at the point c, the ring register operation is activated automatically. That is, the information stored during the first clock change is returned via the S0 port onto the serial input S1. As long as the cycle is not interrupted at c, the data can be read out as often as desired.

## Input circuit

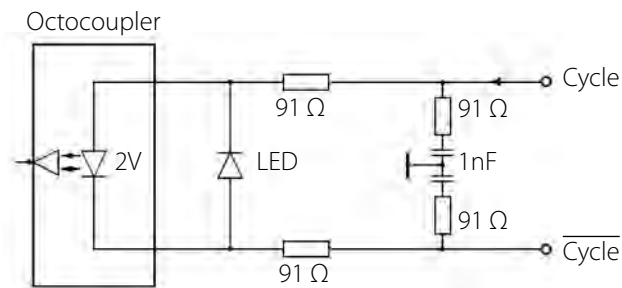

## Output circuit

Driver according to EIA 422 A

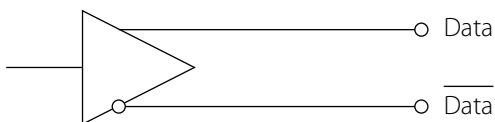

## Recommended data transfer rate

The maximum data transfer rate depends on the cable length.

Cable length	Baud rate
< 50 m	< 400 kHz
< 100	< 300 kHz
< 200 m	< 200 kHz
< 400 m	< 100 kHz

# Series AWA 58

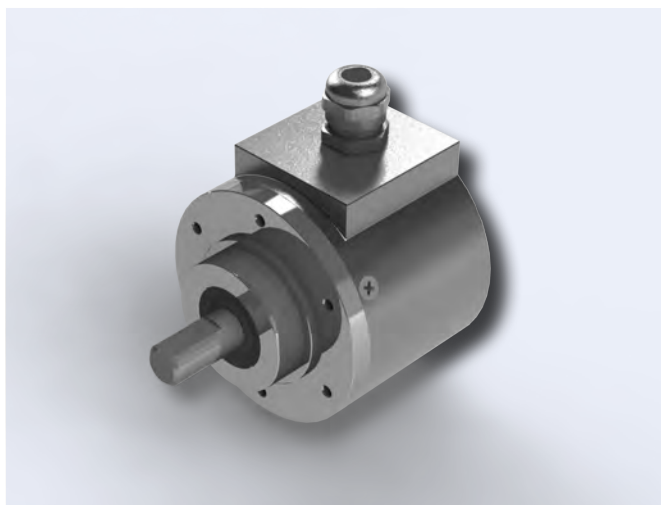

## Series AWA 58

- ▶ Absolute rotary-encoder with a solid shaft diameter of 6-12 mm and parallel output
- ▶ Housing diameter 58 mm, compact design and high degree of protection up to IP67
- ▶ Maximum resolution 10 Bit
- ▶ For highest industrial requirements
- ▶ Also available in stainless steel for aggressive environmental conditions
- ▶ Accessories from page 78

### Electrical specifications

max. pulse frequency:	25 kHz
Perm. temperature range:	-30°... +70° C
Power supply:	10 V... 30 V DC
Max. current consumption:	170 mA (without load)
Max. output load:	40 mA (per channel)
Residual ripple:	max. $\pm 5\% U_B$
Power supply:	5 V DC $\pm 5\%$
Max. current consumption:	80 mA
Max. output load:	30 mA (per channel)

### Mechanical specifications

Flange:	Aluminium
Housing:	Zinc die-casting
Shaft:	stainless steel
Shaft seal:	oil/salt-water resistant
Bearing:	Deep groove ball bearing
Weight:	approx 0,4 kg
Protection type:	IP 65
Max. speed:	6.000 U/min
Torque:	approx 3 Ncm
Max. shaft load:	axial 15 N/radial 30 N

### Mechanical dimensions

A	B	C
6 mm	10 mm	9,5 mm
6,35 mm	10 mm	9,5 mm
8 mm	20 mm	15 mm
9,52 mm	20 mm	15 mm
10 mm	20 mm	15 mm
12 mm	25 mm	20 mm

\* Tolerance = h 6

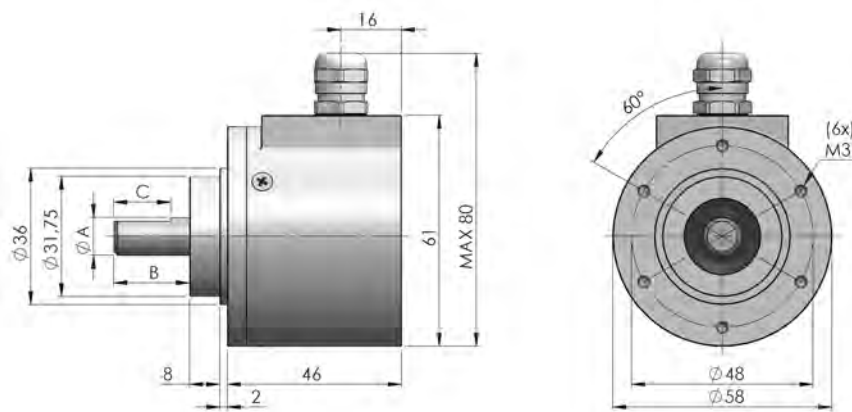

Output circuits

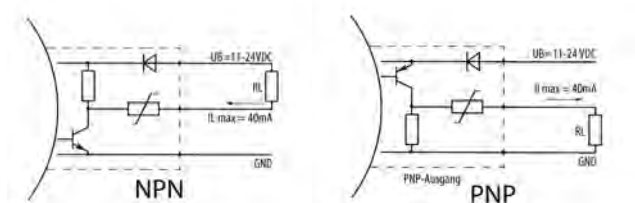

Order ref.: 0

5

Output code	Resolution	Inputs	Option
Gray (beginning with 0)	2, 4, 8, 16, 32, 64, 128, 256, 512, 1.024	Counting direction switchover with GND	none
Gray excess (beginning with ≠ 0)	45, 90, 180, 360		

Pin configuration

Connection type	GND	+U <sub>B</sub>	2 <sub>0</sub>	2 <sub>1</sub>	2 <sub>2</sub>	2 <sub>3</sub>	2 <sub>4</sub>	2 <sub>5</sub>	2 <sub>6</sub>	2 <sub>7</sub>	2 <sub>8</sub>	2 <sub>9</sub>	↔
00	white	brown	green	yellow	gray	pink	blue	red	black	purple	gr/pin	bl/re	ye/br
12	1	2	3	4	5	6	7	8	9	10	11	12	
16	1	2	3	4	5	6	7	8	9	10	11	12	16

Order reference

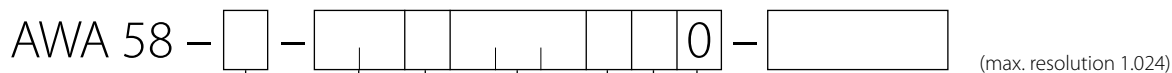

Housing	Shaft	Counting direction	Connection position/ Connection type (see page 78)	Output circuit	Output code	Option
S = Standard E = Stainless steel	06 = 6 mm 08 = 8 mm 10 = 10 mm 12 = 12 mm (IP 54) 56 = 6,35 mm 59 = 9,52 mm	1 = right 2 = left 3 = reversible	Standard: A = axial: 00, 12, 16 R = radial: 00, 12, 16  Stainless steel A = axial: 00, 12, 16 R = radial: 00, 12, 16	0 = NPN 5 = PNP	E = Gray excess G = Gray	0 = none

# Series AWA 90

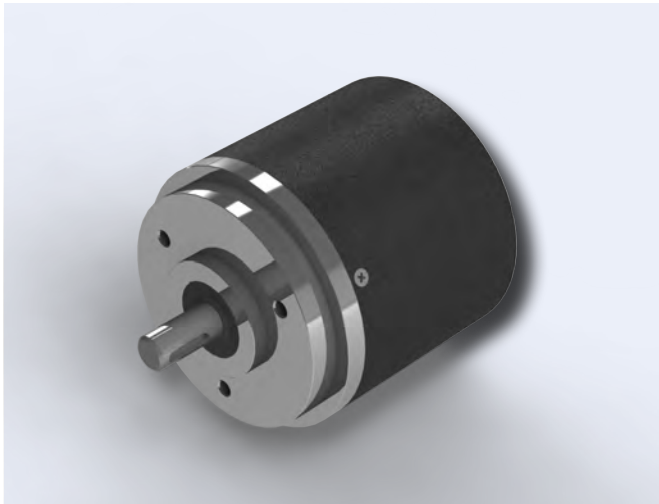

## Series AWA 90

- ▶ Absolute rotary-encoder with a solid shaft diameter of 12 mm and parallel output
- ▶ Housing diameter 90 mm, compact design and high degree of protection
- ▶ Maximum resolution 12 Bit
- ▶ For highest industrial requirements
- ▶ Also available in stainless steel for aggressive environmental conditions
- ▶ Accessories from page 78

### Electrical specifications

Max. step frequency:	25 kHz
Perm. temperature range:	-30° ... +70° C
Power supply:	10 V ... 30 V DC
Max. current consumption:	160 mA (without load)
Max. output load:	40 mA (per channel)
Residual ripple:	max. $\pm 5\% U_B$

### Mechanical specifications

Flange:	Aluminium
Housing:	Powder-coated sheet steel
Shaft:	stainless steel
Shaft seal:	oil/salt-water resistant
Bearing:	Deep groove ball bearing
Weight:	approx 1,2 kg
Protection type:	IP 65
Max. speed:	6.000 U/min
Torque:	approx 5 Ncm
Max. shaft load:	axial 30 N/radial 50 N

### Mechanical dimensions

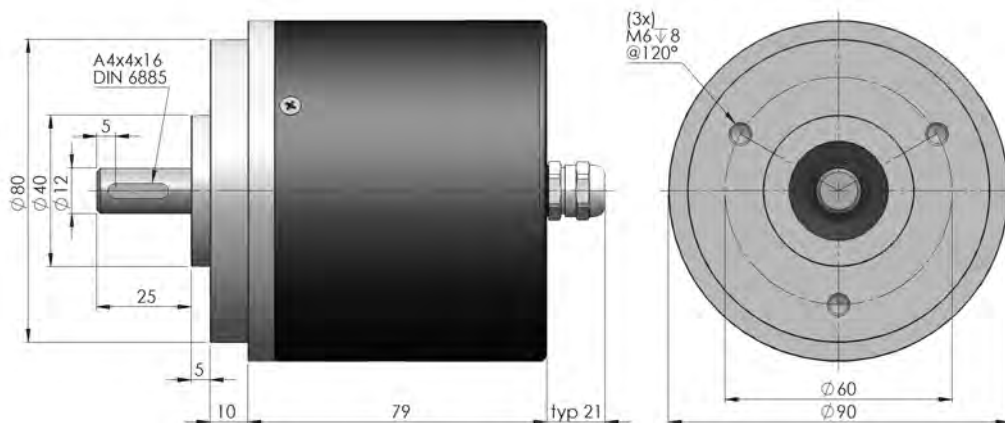

\* Tolerance = h 6



## Output circuits

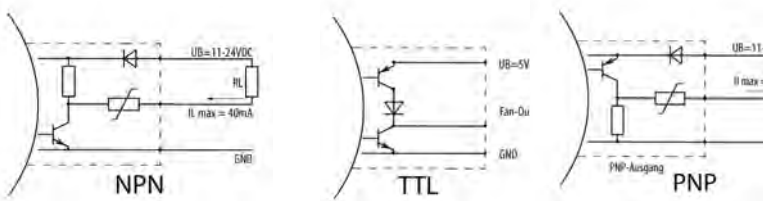

Order ref.: 0

3

5

## Output code

Output code	Resolution	Inputs	Option
Binary, BCD	2, 4, 8, 16, 32, 64, 128, 256, 512, 1.024, 2.048, 3.600, 4.096	(Optocoupler) Counting direction switchover with + U <sub>B</sub>	Latch (Optocoupler input, control with + U <sub>B</sub> )
Gray (beginning with 0)	2, 4, 8, 16, 32, 64, 128, 256, 512, 1.024, 2.048, 4.096		
Gray excess (beginning ≠ 0)	45, 90, 180, 360, 720, 1.440, 2.880, 3.600		

## Pin configuration

Connection type	BCD*		10 <sub>0</sub>				10 <sub>1</sub>				10 <sub>2</sub>				10 <sub>3</sub>				Option	↔
	GND	+ U <sub>B</sub>	1	2	4	8	1	2	4	8	1	2	4	8	1	2	4	Option		
12	1	2	3	4	5	6	7	8	9	10	11	12	-	-	-	-	-	-	-	
16	1	2	3	4	5	6	7	8	9	10	11	12	13	14	15	16	-	-	-	
00	white	brown	green	yellow	gray	pink	blue	red	black	purple	gr/pin	bl/re	wh/gre	br/gre	wh/ye	ye/br	wh/gr	gr/br	wh/pin	

\* as of resolution 2048 BCD, only cable output!

## Order reference

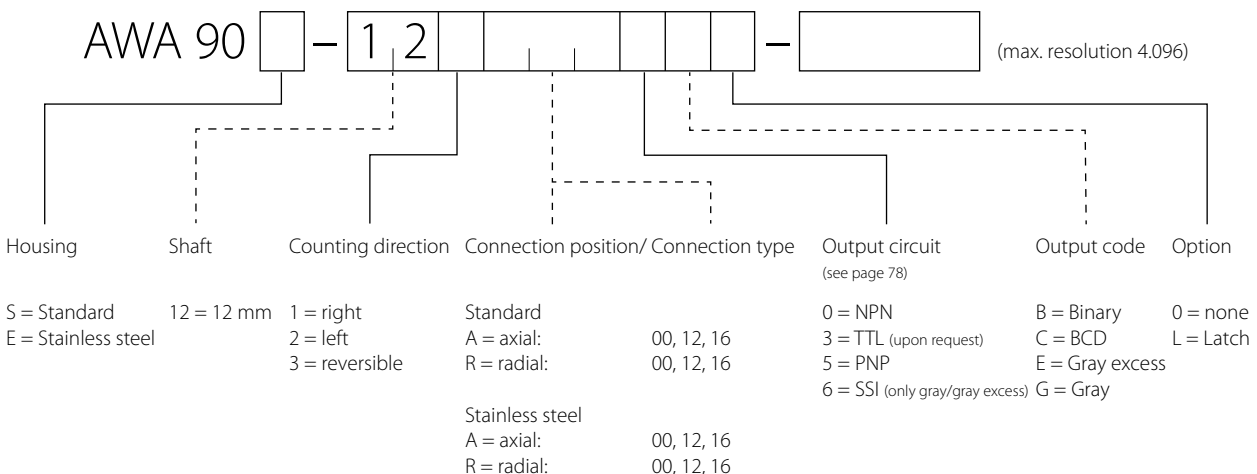

# Series 70 – 140



## Series 70 – 140

- ▶ Absolute rotary-encoder with a solid shaft diameter of 12 mm
- ▶ Housing diameter 102 mm, extrem robust design and high degree of protection
- ▶ Maximum resolution 10 Bit
- ▶ For highest mechanical requirements
- ▶ Low torque
- ▶ Accessories from page 78

### Electrical specifications

max. pulse frequency:	25 kHz
Perm. temperature range:	-30° ... +70° C
Power supply:	10 V ... 30 V DC
Max. current consumption:	100 mA (without load)
Max. output load:	40 mA (per channel)
Residual ripple:	max. $\pm 5\% U_B$

### Mechanical specifications

Housing:	Zinc die-casting
Shaft:	stainless steel
Bearing:	Deep groove ball bearing
Weight:	approx 1,2 kg
Protection type:	IP 54
Max. speed:	6.000 U/min
Torque:	approx 3 Ncm
Max. shaft load:	axial 30 N radial 50 N

### Mechanical dimensions

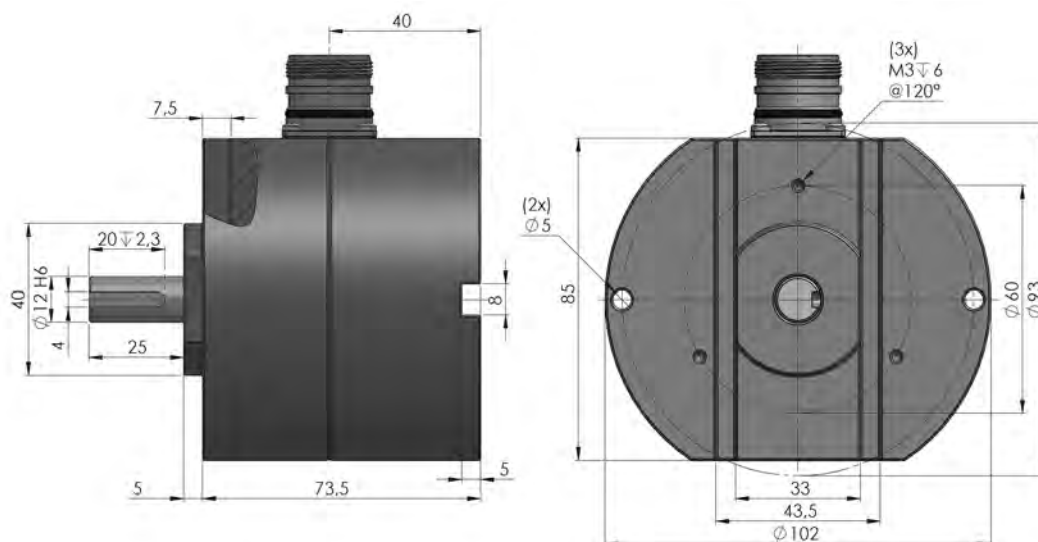

\* Tolerance = h 6  
All specification in millimeters

Output circuits

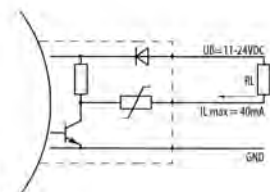

Order ref.: NPN

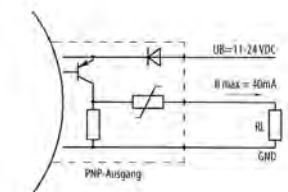

PNP

Output code

Output code	Resolution	Inputs
Binary, BCD	2, 4, 8, 16, 32, 64, 128, 256, 512, 1024	Counting direction switchover (looking at the shaft)
Gray (beginning with 0)	2, 4, 8, 16, 32, 64, 128, 256, 512, 1.024	Input open = right Input + $U_B$ = left
Gray excess (beginning $\neq$ 0)	45, 90, 180, 360, 720	

Pin configuration

Connection type	BCD*		$10_0$				$10_1$				$10_2$				$10_3$	
	GND	+ $U_B$	1	2	4	8	1	2	4	8	1	2	4	8	1	2
F (12 pol.)	1	2	3	4	5	6	7	8	9	10	11	12	-	-	-	-
F (16 pol.)	1	2	3	4	5	6	7	8	9	10	11	12	13	14	15	16
K (00)	white	brown	green	yellow	gray	pink	blue	red	black	purple	green/pink	blue/red	white/green	brown/green	white/yellow	yellow/brown

\* Binary, BCD, only 1024

Order reference



Coding + Count direction + Output

- A = Gray  $\rightarrow$  NPN    E = Bin  $\rightarrow$  NPN    I = BCD  $\rightarrow$  NPN
- B = Gray  $\leftarrow$  NPN    F = Bin  $\leftarrow$  NPN    L = BCD  $\leftarrow$  NPN
- C = Gray  $\rightarrow$  PNP    G = Bin  $\rightarrow$  PNP    K = BCD  $\rightarrow$  PNP
- D = Gray  $\leftarrow$  PNP    H = Bin  $\leftarrow$  PNP    M = BCD  $\leftarrow$  PNP
- N = Gray  $\leftrightarrow$  NPN    P = Bin  $\leftrightarrow$  NPN    S = BCD  $\leftrightarrow$  NPN
- O = Gray  $\leftrightarrow$  PNP    R = Bin  $\leftrightarrow$  PNP    T = BCD  $\leftrightarrow$  PNP

Modification

- A = without
- B = Parity (uneven)
- C = Parity (even)
- F = Connector axial ( $\leftrightarrow$  12 pol.,  $\leftrightarrow$  16 pol.)
- K = Cable output (00)

# Series 72

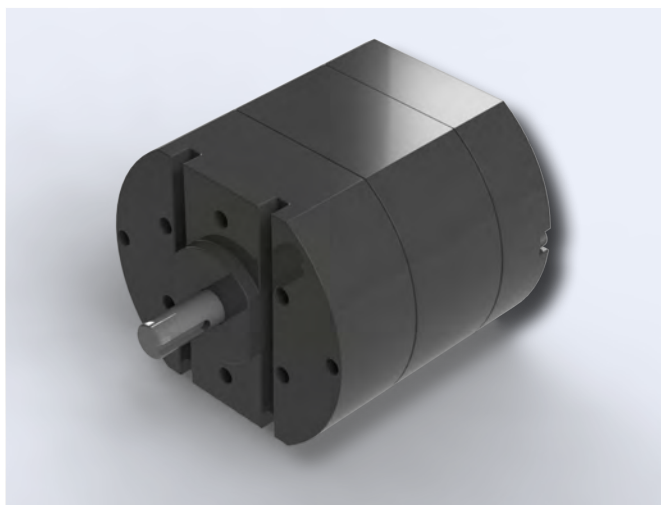

## Series 72

- ▶ Electronic multiturn rotary-encoder with a solid shaft diameter of 12 mm
- ▶ Housing diameter 102 mm, extem robust design and high degree of protection
- ▶ Resolution up to max. 3.600 divisions
- ▶ For highest industrial requirements
- ▶ Low torque
- ▶ 18-bit wider C'Mos counter
- ▶ Integrated accumulator
- ▶ Additional filter circuits
- ▶ Accessories from page 78

### Electrical specifications

Max. step frequency:	25 kHz
Perm. temperature range:	-30°... +70° C
Power supply:	10 V... 30 V DC
Max. current consumption:	120 mA
Power failure safety:	max. 48 hrs.

### Mechanical specifications

Housing:	Zinc die-casting
Flange:	Zinc die-casting
Shaft:	stainless steel 12 mm
Bearing:	Deep groove ball bearing
Weight:	approx 1,2 kg
Protection type:	IP 54 according to DIN 40050
Max. speed:	6.000 U/min
Moment of inertia:	270 gcm <sup>2</sup>
Torque:	3 Ncm
Max. shaft load:	axial 10 N radial 10 N

### Mechanical dimensions

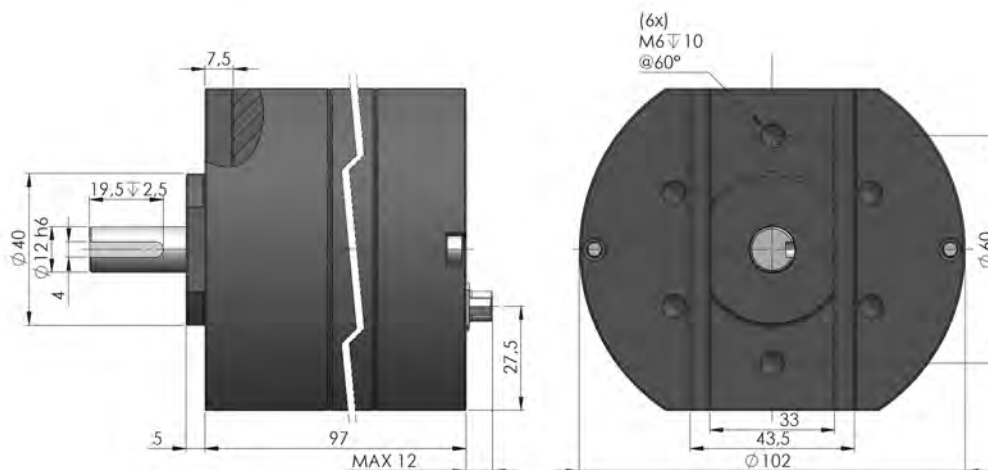

All specification in millimeters

### Output circuits

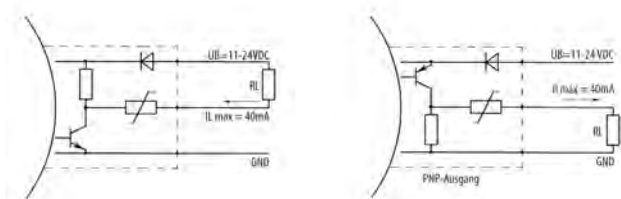

Order ref.: NPN

PNP

### Output signals

#### Binär-Code

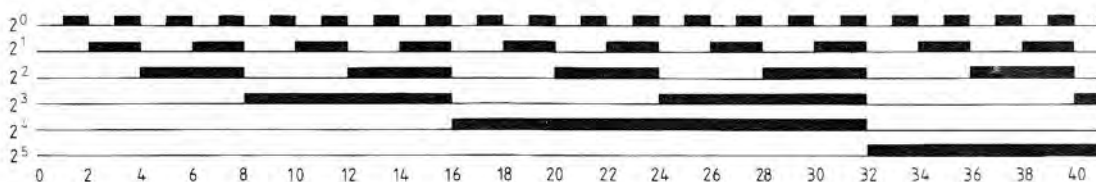

#### BCD-Code

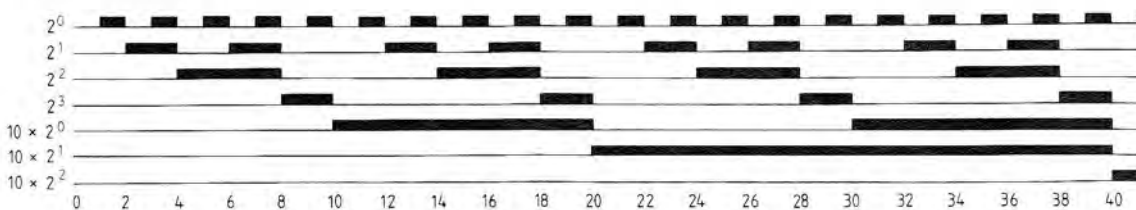

### Order reference

Series 72 1,4,0 U     -   Division up to max. 3.600 (as of 2, each division available by 2)

Mech. Design  
140 = Standard

Coding + Count direction  
U\* = Bin ↔ 18-bit = 262 144  
or  
BCD ↔ 18-bit = 39 999

\* reversible

Output circuit  
N = NPN (current sink)  
P = PNP (current source)

Modification  
B = without buffer  
C = Standard  
D = Reset pulse  
K = Cable output  
Z = ext. buffer

### Special versions (on request)

- External buffering
- Without buffering
- Cable output
- Flange-triggered reset pulse

# Series 72

## Functional description of the control inputs

Pin	Desc.	Explanation
25 *	Reset Acknowledgement Alarm	A signal (+ Ub) resets the internal counter. The alarm output is acknowledged at the same time.
24 *	Code Selection of output code	A signal (+ Ub) switches the code type from binary to BCD code
23 *	Change of counting direction	A signal (+ Ub) changes the counting direction. Looking at the shaft: Sequence of numbers increasing for an anticlockwise shaft)
22	Alarm/Relay output Unilateral mass of switching	When the internal battery no longer has sufficient voltage and counting errors could arise, this is indicated by resetting the output. Furthermore, the internal power supply is monitored during operation.

\* All control inputs are switched via octocoupler

## Functional description of alarm output: (after applying the operating voltage)

The counter is reset and the alarm output is acknowledged by resetting.

The alarm output is only set when the battery voltage has exceeded a certain value during actuation of the reset.

This depends on the battery discharge and can take a few minutes.

If the reset is controlled with a static signal of + Ub, the release of the count is signalled by setting the alarm output.

### Options:

Option1/Pin 21: Acknowledgement input for alarm signal independent of reset

Option2/Pin 21.22: Potential-free relay contact for alarm signal

Pin configuration type 72-140 U...

Pin	25-pole connector		Wire colour at cable output (DIN 47 100)
	Valence for binary code	Valence for BCD code	
1	–	–	white
2	+	+	brown
3	$2^0$	1	green
4	$2^1$	2	yellow
5	$2^2$	4	gray
6	$2^3$	8	pink
7	$2^4$	1	blue
8	$2^5$	2	red
9	$2^6$	4	black
10	$2^7$	8	purple
11	$2^8$	1	gray-pink
12	$2^9$	2	blue-red
13	$2^{10}$	4	white-green
14	$2^{11}$	8	brown-green
15	$2^{12}$	1	white-yellow
16	$2^{13}$	2	yellow-brown
17	$2^{14}$	4	white-gray
18	$2^{15}$	8	gray-brown
19	$2^{16}$	1	white-pink
20	$2^{17}$	2	pink-brown
21	Option	Option	white-blue
22	Alarm	Alarm	brown-blue
23	↔	↔	white-red
24	Binary / BCD	Binary / BCD	brown-red
25	Reset	Reset	white-black

# Series BC 58



## Series BC 58

- ▶ Absolute single- and multiturn rotary-encoder with solid shaft or blind hollow shaft
- ▶ Housing diameter 58 mm, compact design and high degree of protection up to IP67
- ▶ Maximum resolution singleturn 17 Bit
- ▶ Maximum resolution multiturn 25 Bit
- ▶ For highest industrial requirements
- ▶ Available interfaces: Parallel, SSI, ProfibusDP, Interbus K2 and K3, DeviceNet, CAN, CANopen
- ▶ Accessories from page 78

### Mechanical specifications

Shaft diameter	6 mm (synchro flange) 10 mm (clamping flange) 10/12 mm (blind hollow shaft)
Shaft load	axial 40 N, radial 60 N (10, 12 mm shaft)
Speed	Continuous operation 10.000 min <sup>-1</sup>
Torque	< 0.5 Ncm
Moment of inertia	ca. 3,8 x 10 <sup>-6</sup> kgm <sup>2</sup>
Protection class	Shaft input IP 64 or IP 67, housing IP 67
General design	according to DIN EN 61010, protection class III, degree of contamination 2, overvoltage category II
Operating temperature	- 40 ... 100 ° C
Storage temperature	- 40 ... 85 ° C
Vibration resistance	DIN EN 60068-2-6, 100 m/s <sup>2</sup> (10 ... 2.000 Hz)
Shock resistance	DIN EN 60068-2-27, 1.000 m/s <sup>2</sup> (6 ms)
Connection	axial or radial
Flange	S = Synchro flange K = Clamping flange F = Blind hollow shaft
Starting torque	< 0,01 Nm
Mass	Singleturn approx 350 g, Multiturn approx 400 g



**Mechanical dimensions**

Synchro flange („S“)

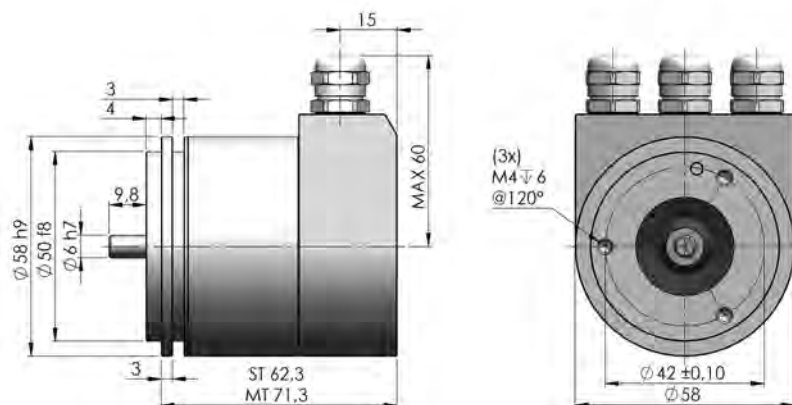

Clamping flange („K“)

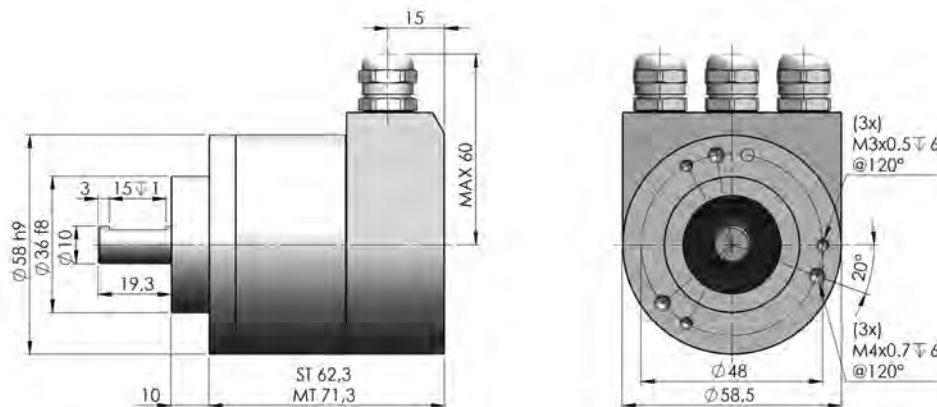

Blind hollow shaft („F“)

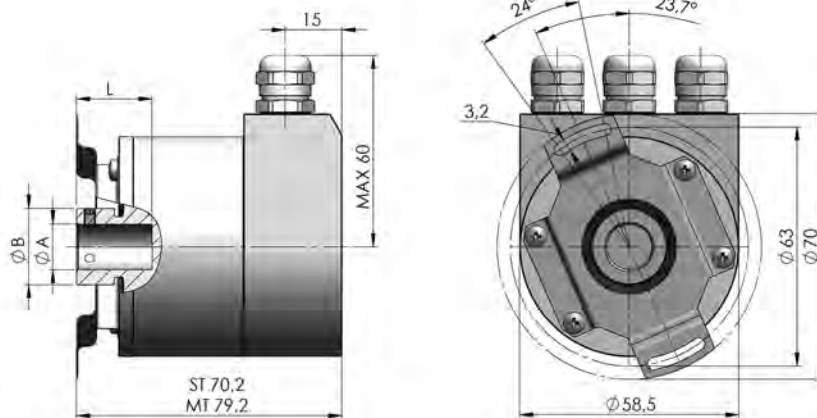

Hollow shafts $\varnothing A$	10 <sup>+0,012</sup> mm	12 <sup>+0,012</sup> mm
Connecting shafts $\varnothing C$	10 <sub>g7</sub> mm	12 <sub>g7</sub> mm
Clamping ring $\varnothing B$	18 mm	20 mm
L min.	15 mm	18 mm
L max.	20 mm	20 mm
Shaft code	„2“	„7“

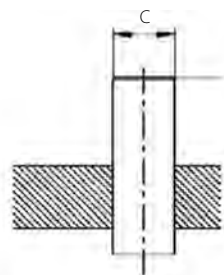

# Series BC 58

## BC 58 with parallel interface - Singleturn with cable

Colour (PVC)	10 Bit	12 Bit	13 Bit	14 Bit
gray/pink	N.C.	N.C.	N.C.	S0 (LSB)
brown/yellow	N.C.	N.C.	S0 (LSB)	S1
brown/gray	N.C.	S0 (LSB)	S1	S2
red/blue	N.C.	S1	S2	S3
purple	S0 (LSB)	S2	S3	S4
white/brown	S1	S3	S4	S5
white/green	S2	S4	S5	S6
white/yellow	S3	S5	S6	S7
white/gray	S4	S6	S7	S8
white/pink	S5	S7	S8	S9
white/blue	S6	S8	S9	S10
white/red	S7	S9	S10	S11
white/black	S8	S10	S11	S12
brown/green	S9 (MSB)	S11 (MSB) Tristate	S12 (MSB)	S13 (MSB)
yellow	Tristate S0...S9	S0... S11 Latch	Tristate S0...S1	Tristate S0...S13
pink	Latch (only binary)	Latch (only binary)	Latch (only binary)	Latch (only binary)
green	Direction	Direction	Direction	Direction
black	0 V	0 V	0 V	0 V
red	5 V/10...30 V DC	5 V/10...30 V DC	5 V/10...30 V DC	5 V/10...30 V DC
brown	Alarm	Alarm	Alarm	Alarm

## BC 58 with parallel interface - Singleturn with flange receptacle, 17-pol.

Pin	10 Bit	12 Bit	13 Bit	14 Bit
1	S0 (LSB)	S0	S12 (MSB)	S13 (MSB)
2	S1	S1	S11	S12
3	S2	S2	S10	S11
4	S3	S3	S9	S10
5	S4	S4	S8	S9
6	S5	S5	S7	S8
7	S6	S6	S6	S7
8	S7	S7	S5	S6
9	S8	S8	S4	S5
10	S9 (MSB)	S9	S3	S4
11	N.C.	S10	S2	S3
12	Tristate S0..S9	S11 (MSB) Latch	S1	S2
13	Latch (only binary)	Latch (only binary)	S0 (LSB)	S1
14	Direction	Direction	Direction	S0 (LSB)
15	0 V	0 V	0 V	0 V
16	5 V/10...30 V DC	5 V/10...30 V DC	5 V/10...30 V DC	5 V/10...30 V DC
17	Alarm	Alarm	Alarm	Alarm

BC 58 with parallel interface - Multiturn (PVC cable)

Colour	Configuration	Colour	Configuration	Colour	Configuration
brown	S 0	yellow/brown	S 11	gray/green	M 10 2)
green	S 1	white/gray	M 0	yellow/gray	M 11 2)
yellow	S 2	gray/brown	M 1	pink/green	Alarm
gray	S 3	white/pink	M 2	yellow/pink	Direction
pink	S 4	pink/brown	M 3	green/blue	Latch
purple	S 5	white/blue	M 4 1)	yellow/blue	Tristate
gray/pink	S 6	brown/blue	M 5 1)	red (0.5 mm <sup>2</sup> )	10 ... 30 V DC
red/blue	S 7	white/red	M 6 1)	white (0.5 mm <sup>2</sup> )	10 ... 30 V DC
white/green	S 8	brown/red	M 7 1)	blue (0.5 mm <sup>2</sup> )	0 V
brown/green	S 9	white/black	M 8 2)	black (0.5 mm <sup>2</sup> )	0 V
white/yellow	S 10	brown/black	M 9 2)		

1) N.C. with resolution 16-bit  
 2) N.C. with resolution 16- or 20-bit

Electrical specifications

Supply voltage	10-30 V
Intrinsic current consumption	ST 200 mA/MT 300 mA
Interface	Parallel
Output code	Binary, Gray, Gray excess
Resolution singleturn	10-14-bit, depending on variant, 12-bit in MT design Gray excess: 360, 720 steps
Resolution multiturn	12-bit
Linearity	+/- 1/2 LSB
Output current	30 mA per bit Short-circuit-proof
Control inputs	Latch, Direction, Tristate by ST; Tristate by MT
Connection	Cable or flange receptacle, Conin 17-pol. Axial or radial, Sub D 37-pol.

Order reference

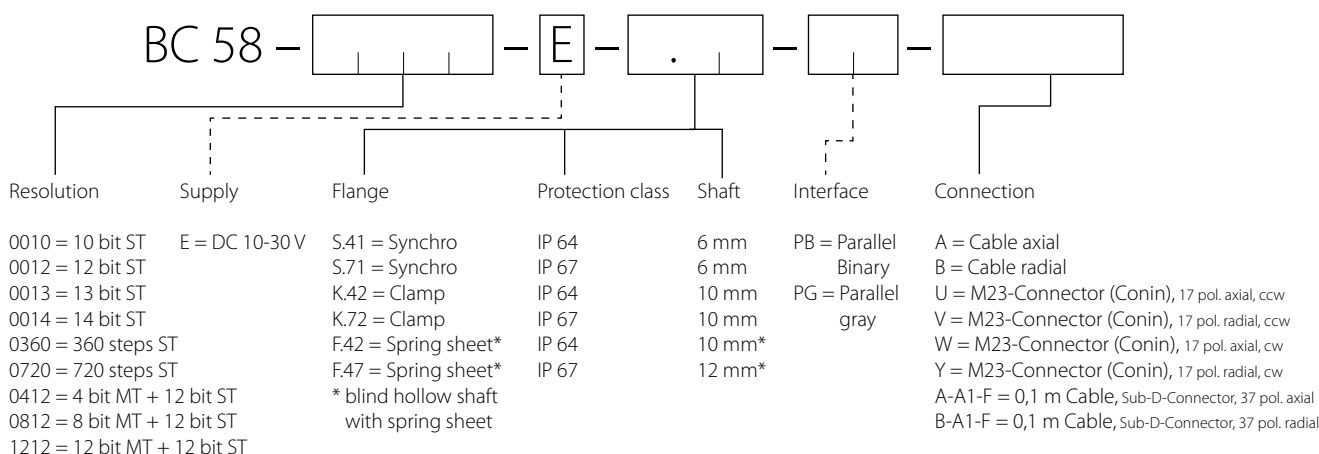

# Series BC 58

## BC 58 with SSI interface

### Synchronous serial transmission (SSI) for absolute rotary encoders

The SSI interface can be used for multiturn encoders with gray code or binary code. Furthermore, special bits (alarm signal, parity) can be attached to the data bits of the 24-bit encoder.

The SSI interface supports single and multiple transfers. For multiple transfer (the stored value is read out several times in succession), a fixed number of cycles per revolution must be observed (25 to 26 cycles for multiturn).

For multiple transfer, the distance between the clock brush must be below 10  $\mu\text{s}$  and for single transfer, it must be greater than 30  $\mu\text{s}$ . After the output of the last bit (alarm or parity), the data output for approx. 20  $\mu\text{s}$  is set to logic „0“, then to logic „1“. Then current encoder data can be read out again.

### Recommended data transfer rate for SSI

The maximum data transfer rate depends on the cable length.

Cable length	Baud rate
< 50 m	< 400 KHz
< 100 m	< 300 KHz
< 200 m	< 200 KHz
< 400 m	< 100 KHz

### Pin configuration SSI interface

Cable	Flange receptacle	Signal
brown (0.5 mm <sup>2</sup> )	1	0 V (supply voltage)
pink	2	Data
yellow	3	Cycle
	4	N.C.
blue	5	$\overline{\text{Direction}}$
	6	N.C.
	7	N.C.
white (0.5 mm <sup>2</sup> )	8	10 ... 30 V DC
	9	N.C.
gray	10	$\overline{\text{Data}}$
green	11	$\overline{\text{Cycle}}$
black	12	0 V- Signal output

BC 58 with SSI interface

Electrical	
Supply voltage	5 V or 10-30 V
Intrinsic current consumption	Singleturn 50 mA/Multiturn 100 mA
Interface	Standard SSI
Output code	Binary or gray
Resolution singleturn	10-17-bit, depending on variant, max. 13-bit in MT Gray excess: 360, 720 steps
Absolute accuracy	+/- 35 ''
Repeat accuracy	+/- 7 ''
Status LED	Green = ok; Red = Alarm
Control inputs	Direction
Parametrisable	Resolution, code type, direction of rotation, warning, alarm
Reset button	Lockable per parametrisation
Connection	Cable or flange receptacle Conin axial or radial

Order reference

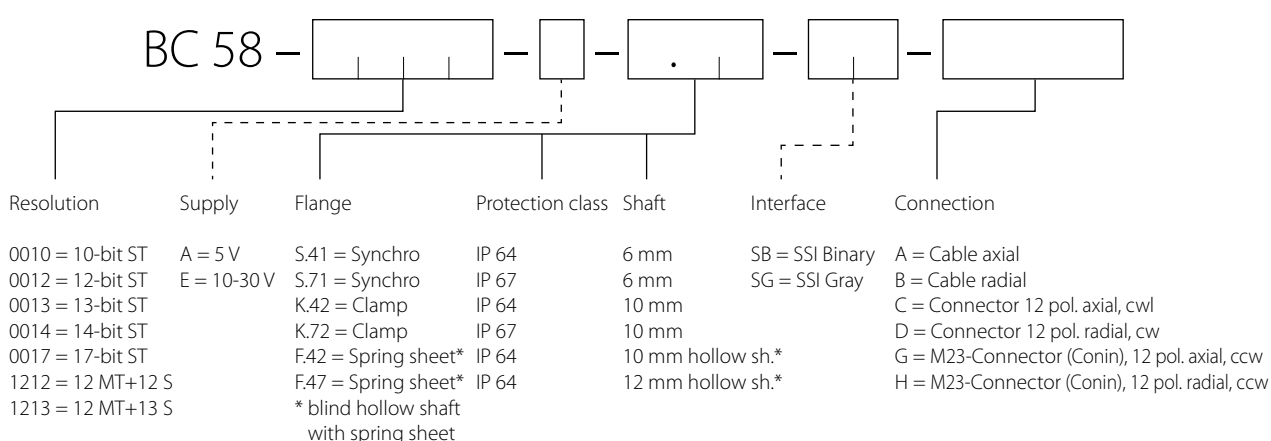

# Series BC 58

## BC 58 with Profibus DP interface

Electrical	
Supply voltage	11-30 V DC
Intrinsic current consumption	Singleturn 220 mA/Multiturn 250 mA
Interface	Profibus-DP, Encoder Profile
Certified	PNO
Programmable	According to class 2: Resolution, Preset*, Direction
Output code	Binary
Baud rate	9.6 K Baud - 12 M Baud
Resolution singleturn	10 - 14-bit, depending on variant
Resolution multiturn	12-bit
Integrated special function	Speed, acceleration, operating time
Connection	Bus cover with 2 connectors, bus cover with 3-fold PG gland
Mechanical	
operating temperature	- 40° C to + 85° C
Mass, approx.	Singleturn 350 g/Multiturn 400 g

\* Preset only via bus, no button

## Order reference

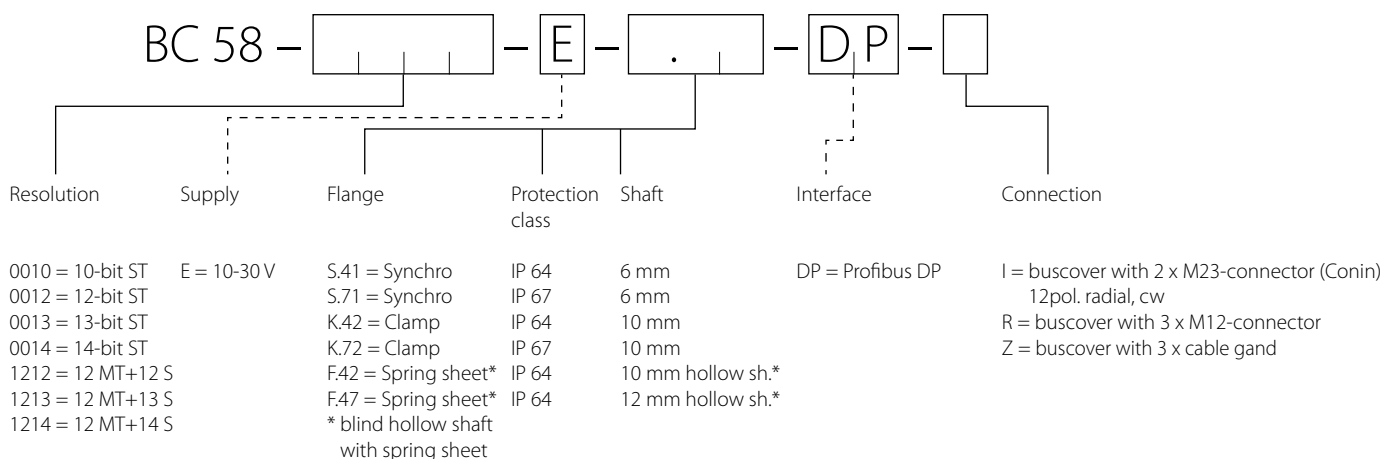

**BC 58 with Interbus interface**

Electrical	
Supply voltage	11-30 V DC
Intrinsic current consumption	Singleturn 220 mA/Multiturn 250 mA
Interface	Interbus, ENCOM Profile K 3 (parametrisable), K 2
DÜ Format	Supi address 0123, Byte no. 3210
Programmable	Direction, scaling factor, preset, offset
Output code	32-bit binary
Baud rate	500 Kbaud according to ENCOM
Resolution singleturn	Singleturn 10 - 17-bit, depending on variant, 12-bit in MT design
Resolution multiturn	12-bit
ID code k 3	37H (055 decimal)
Connection	Bus cover with 2 connectors, bus cover with 3-fold PG gland
Mechanical	
Operating temperature	- 40° C to + 85° C
Mass, approx.	Singleturn 350 g/Multiturn 400 g

**Order reference**

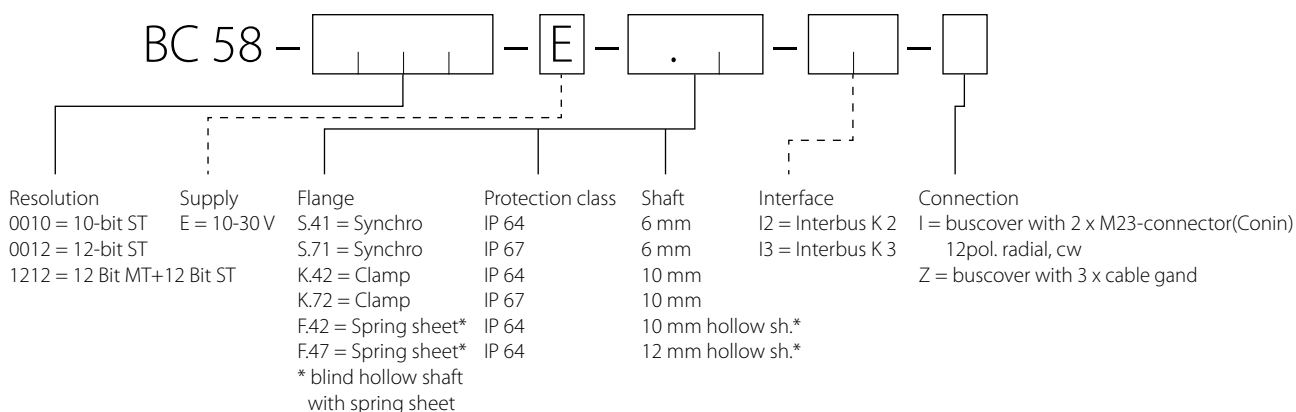

# BC 58

## BC 58 with DeviceNet interface

Electrical	
Supply voltage	11-30 V DC
Intrinsic current consumption	Singleturn 220 mA/Multiturn 250 mA
Interface	CAN-Highspeed according to ISO/DIS 11898, CAN specifications 2.0 B
Certified	PNO
Programmable	According to class 2: Resolution, Preset*, Direction
Output code	Binary
Baud rate	Adjustable 125, 250, 500 Kbaud
Resolution singleturn	10 - 14-bit, depending on variant, 12-bit in MT design
Resolution multiturn	12-bit
Transfer mode	Polling mode (only upon request), Change of State (automatic with value change), Cyclical with adjustable cycle timer
Connection	Bus cover with 2 connectors, bus cover with 3-fold PG gland
Mechanical	
Operating temperature	- 40° C to + 85° C
Mass, approx.	Singleturn 350 g/Multiturn 400 g

\* Preset only via bus, no button

## Order reference

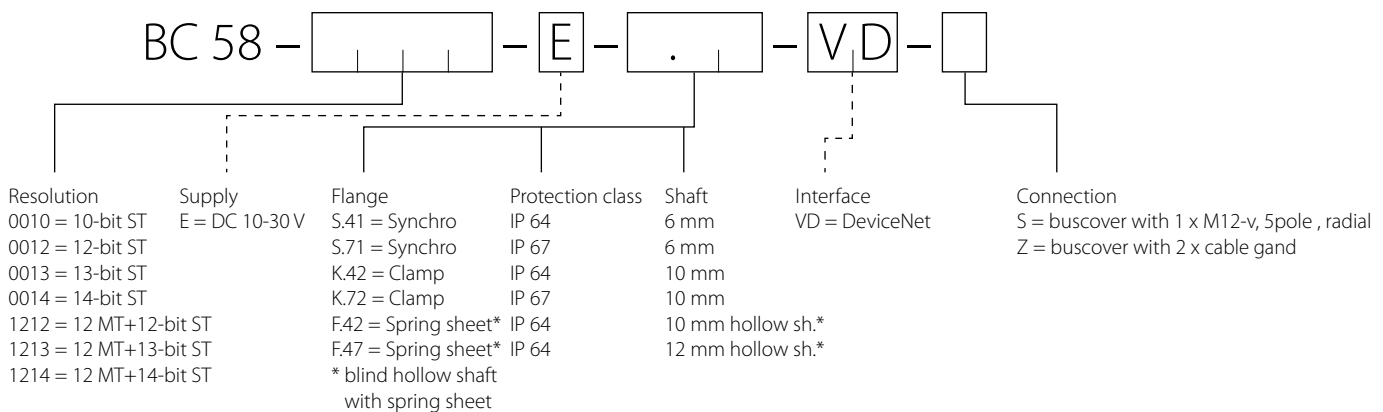



**BC 58 with CANopen/CAN Layer 2 interface**

Electrical	
Supply voltage	11-30 V DC
Intrinsic current consumption	Singleturn 220 mA/Multiturn 250 mA
Interface	CAN-Highspeed according to ISO/DIS 11898, Basic and Full CAN CAN specifications 2.0 B (11 and 29-bit identifier)
Profile	Profile CANopen according to Profile DSP 406, with additional functions
Programmable	CANopen: Direction, resolution, preset, offset, Limit values: CAN L2: Direction, limit values, binary
Output code	32-bit binary
Baud rate	Adjustable 10 to 1.000 Kbaud
Base identifier	Adjustable via DIP switch
Integrated special function	Speed, acceleration/rotary axle, limit values only CANopen
Resolution singleturn	Singleturn 10 - 14-bit, depending on variant, 12-bit in MT design
Resolution multiturn	12-bit
Transfer mode	Polling mode (only upon request), Change of State (automatically with value change), cyclical with adjustable cycle timer
Connection	Bus cover with 2 connectors, bus cover with 3-fold PG gland
Mechanical	
Operating temperature	- 40° C to + 85° C
Mass, approx.	Singleturn 350 g/Multiturn 400 g

**Order reference**

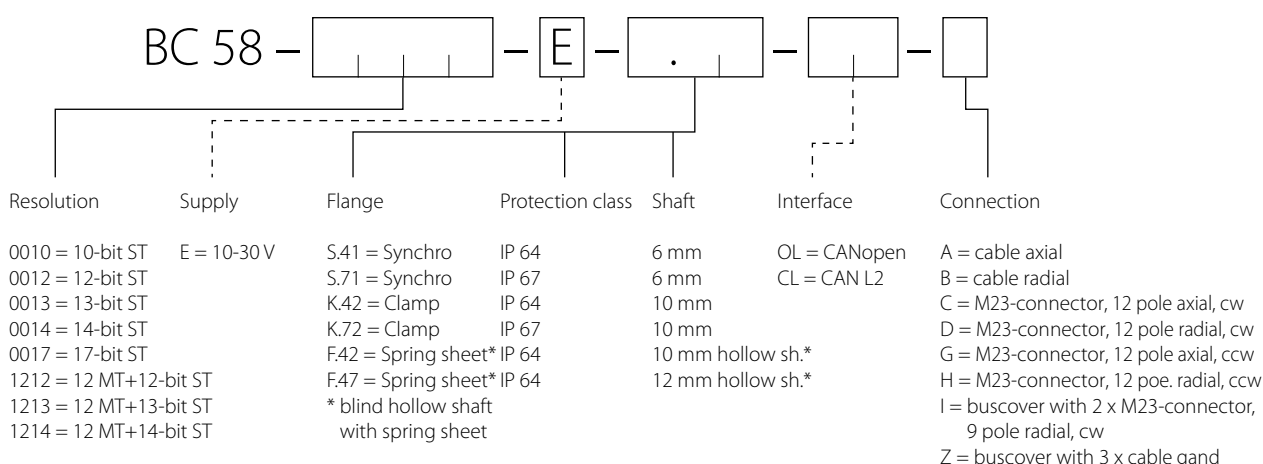

# Series PS & PSM



## Series PS & PSM

- ▶ Absolute single- and multiturn rotary-encoder with solid shaft or blind hollow shaft
- ▶ Housing diameter 58 mm, compact design and high degree of protection up to IP67
- ▶ Maximum resolution singleturn 16 Bit
- ▶ Maximum resolution multiturn 30 Bit
- ▶ For highest industrial requirements
- ▶ ProfiNet, Power link, Ethernet/TCP/IP, Ethernet IP or EtherCat interface
- ▶ Accessories from page 78

### Electrical specifications

Supply voltage:	10-30 V +/- 5%
Power:	max. 4 watt
Interface:	Ethernet
Protocol:	ProfiNet (NRT, RT, IRT)
Transfer rate:	100 MBit/s
Cycle time	<= 1 ms (IRT); <= 10 ms (RT)
Resolution:	Singleturn 16-bit Multiturn 30-bit (16-bit singleturn - 14-bit multiturn)
Linearity	+/- 2 LSB x 16-bit, 1 LSB x 14-bit +/- 1/2 LSB 12-bit
Output code:	Binary
Programmability:	Resolution turn Resolution total Preset
Terminating resistor:	adjustable with DIP switches
Operating temperature:	Standard -40° C ... +85° C

### Mechanical specifications

Housing:	Aluminium
Flange:	Aluminium
Shaft:	stainless steel
Bearing:	2 ball bearings
Weight:	400 g
Protection type:	IP 67
Max. speed:	6.000 U/min
Torque:	< 0.5 Ncm
Moment of inertia:	20 g/cm <sup>2</sup>
Max. shaft load:	axial 20 N - Rad 40 N axial 40 N - Rad 60 N

### Mechanical dimensions

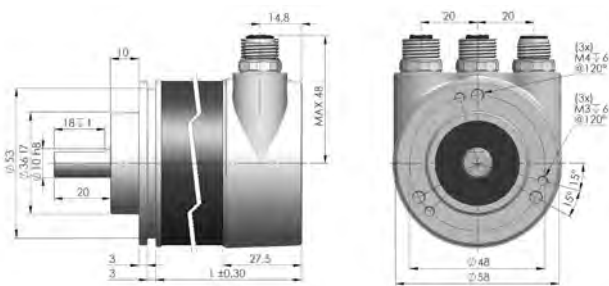

#### Flange 1H

Singeltturn \*L = 69,00 / Multiturn \*L = 80,00

\*Tolerance = ± 0,2 / All specification in millimeters

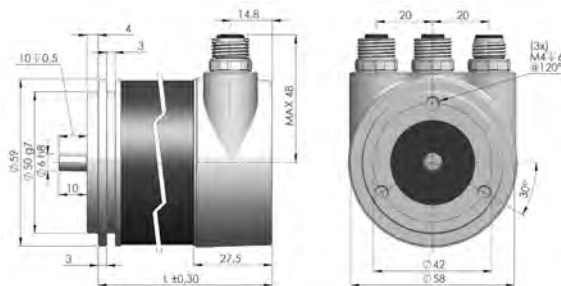

#### Flange 13 / Flange 33

Singeltturn \*L = 69,00 / Multiturn \*L = 80,00

\*Tolerance = ± 0,2 / All specification in millimeters

Mechanical dimensions

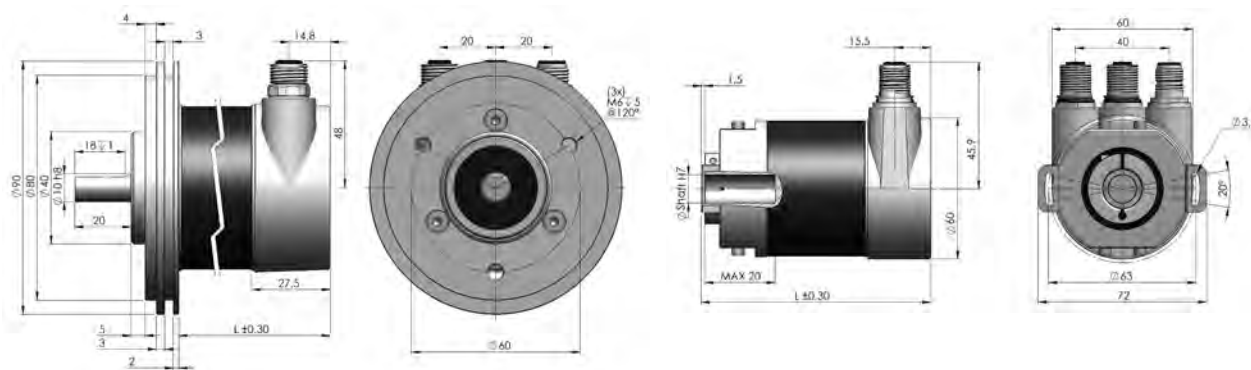

Flange T1

Singleturn \*L = 69,00 / Multiturn \*L = 80,00  
 \* Tolerance = ± 0,2 / All specification in millimeters

Blind hollow shaft with spring sheet

B8 = Ø 10 mm, C8 = Ø 12 mm, E8 = Ø 15 mm  
 \* Tolerance = ± 0,2 / All specification in millimeters

Order reference

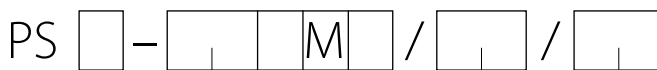

Design	Shaft/ Flange	Output	Connection	Option	Bit Singleturn	Bit Multiturn
S = Singleturn M = Multiturn	solid shaft 1H = Ø 10 mm, length 20 mm Clamping flange 13 = Ø 10 mm, length 20 mm Synchro flange 33 = Ø 6 mm, length 10 mm Synchro flange 1T = Ø 10 mm, length 20 mm Adapter Synchro flange Ø 90 mm 16 = Ø 10 mm, length 20 mm Square flange blind hollow shaft with spring sheet B8 = Ø 10 mm C8 = Ø 12 mm E8 = Ø 15 mm	5 = ProfiNet optical A = PowerLink B = EtherNet TCP/IP C = Ethernet IP D = EtherCat	M = 3 x M12 4-Pin radial	P = none C = INOX AISI 304	13 = 13 Bit 16 = 16 Bit	12 = 12 Bit 14 = 14 Bit

# Series HWA 103

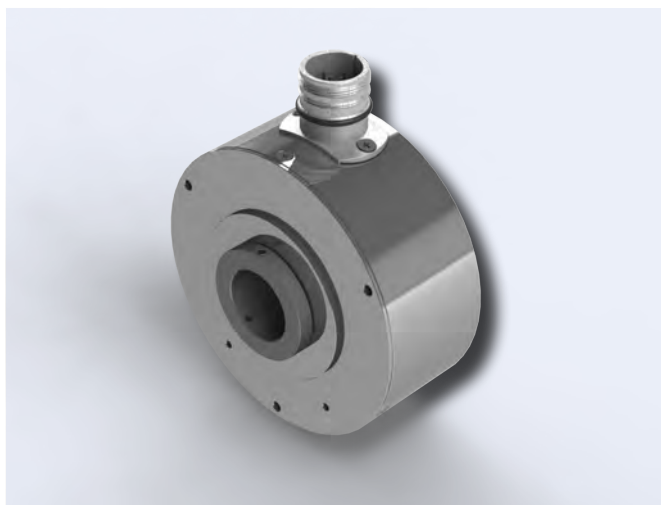

## Series HWA 103

- ▶ Absolute singleturn rotary-encoder with a hollow shaft diameter of 10-25,4 mm, parallel- or SSI output
- ▶ Housing diameter 103 mm, small design and high degree of protection
- ▶ Maximum resolution 12 Bit
- ▶ Direct assembly onto existing shafts
- ▶ Also available in stainless steel for aggressive environmental conditions
- ▶ Accessories from page 78

### Electrical specifications

max. pulse frequency:	25 kHz
Perm. temperature range:	-30° ... +70° C
Power supply:	10 V ... 30 V DC
Max. current consumption:	160 mA (without load)
Max. output load:	40 mA (per channel)
Residual ripple:	max. $\pm 5\% U_B$

### Mechanical specifications

Flange:	Aluminium
Housing:	Aluminium
Hollow shaft:	stainless steel
Shaft seal:	oil/salt-water resistant
Bearing:	Deep groove ball bearing
Weight:	approx 0,8 kg
Protection type:	IP 65
Max. speed:	6.000 U/min
Torque:	approx 15 Ncm

### Mechanical dimensions

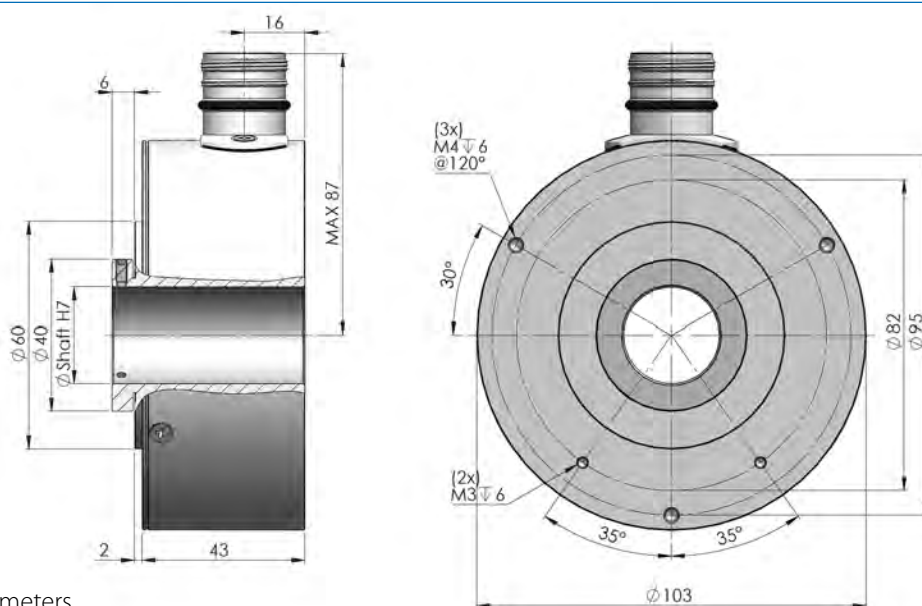

\* Tolerance = H 7  
All specification in millimeters

Output circuits

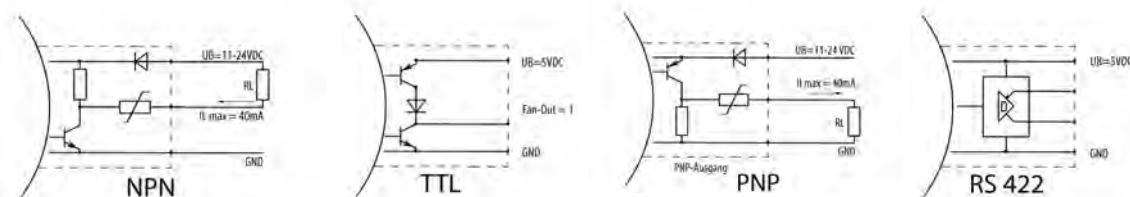

Order ref.: 0

3

5

6

Output code

Output code	Resolution	Inputs	Option
Binary, BCD	2, 4, 8, 16, 32, 64, 128, 256, 512, 1.024, 2.048, 3.600, 4.096	(Octocoupler) Counting direction switchover with + U <sub>B</sub>	Latch (Octocoupler input, control with + U <sub>B</sub> )
Gray (beginning with 0)	2, 4, 8, 16, 32, 64, 128, 256, 512, 1.024, 2.048, 4.096		
Gray excess (beginning ≠ 0)	45, 90, 180, 360, 720, 1.440, 2.880, 3.600		

Pin configuration

Connection type	BCD*		10 <sub>0</sub>				10 <sub>1</sub>				10 <sub>2</sub>				10 <sub>3</sub>				Option	↔
	GND	+ U <sub>B</sub>	1	2	4	8	1	2	4	8	1	2	4	8	1	2	4			
12	1	2	3	4	5	6	7	8	9	10	11	12	-	-	-	-	-	-	-	
16	1	2	3	4	5	6	7	8	9	10	11	12	13	14	15	16	-	-	-	
00	white	brown	green	yellow	gray	pink	blue	red	black	purple	gr/pin	bl/re	ws/gre	br/gre	wh/ye	ye/br	wh/gr	gr/br	wh/pin	

\* as of resolution 2048 BCD, only cable output!

Order reference

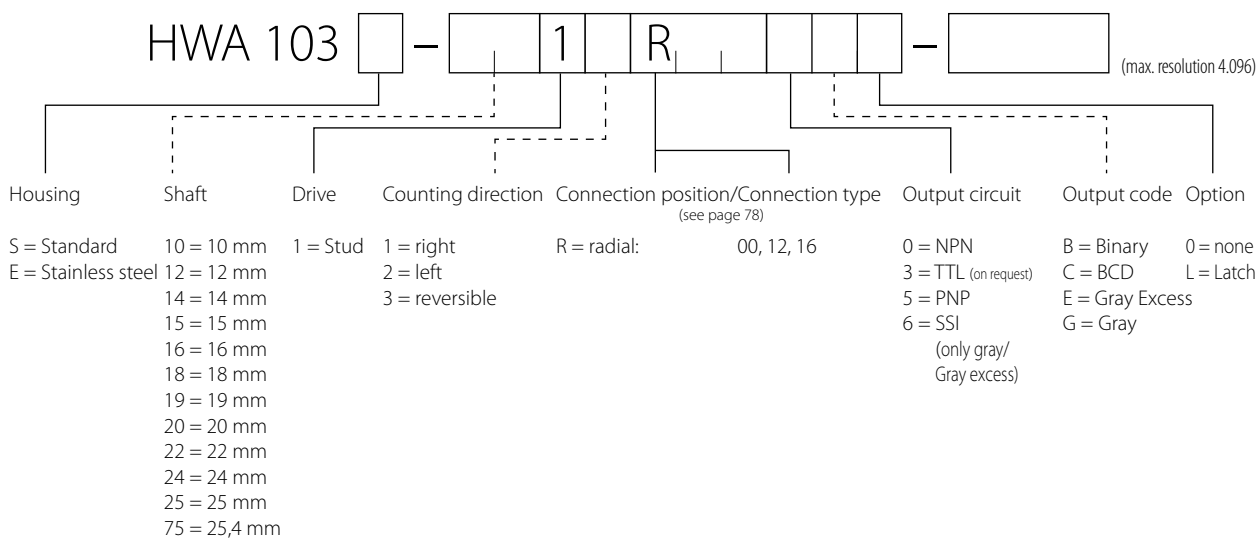

# Series SWA 90

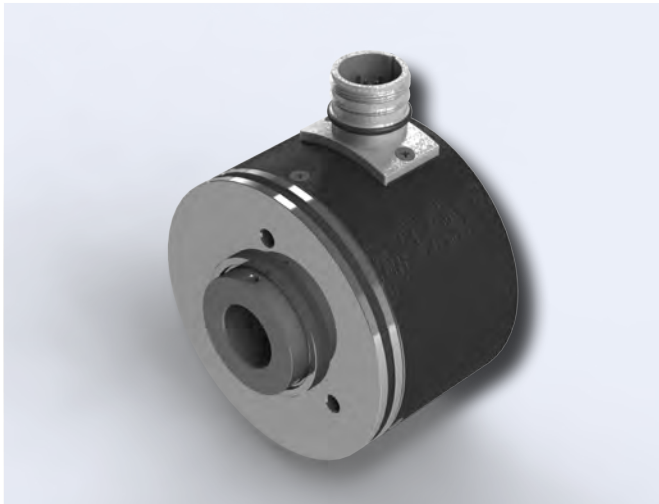

## Series SWA 90

- ▶ Absolute singleturn rotary-encoder with a blind hollow shaft diameter of 20 mm and parallel output
- ▶ Housing diameter 90 mm, small design and high degree of protection
- ▶ Maximum resolution 12 Bit
- ▶ Direct assembly onto existing shafts
- ▶ Accessories from page 78

### Electrical specifications

max. pulse frequency:	25 kHz
Perm. temperature range:	-30° C ... +60° C
Power supply:	10 V ... 30 V DC + 20 %
Max. current consumption:	160 mA (without load)
Max. output load:	40 mA (per channel)
Residual ripple:	max. $\pm 5\%$ $U_B$

### Mechanical specifications

Flange:	Aluminium
Housing:	Powder-coated sheet steel
Hollow shaft:	stainless steel
Shaft seal:	oil/salt-water resistant
Bearing:	Groove ball bearing
Weight:	ca. 1,2 kg
Protection type:	IP 65
Max. speed:	6.000 U/min
Torque:	ca. 5 Ncm
Max. shaft load:	axial 30 N / radial 50 N

### Mechanical dimensions

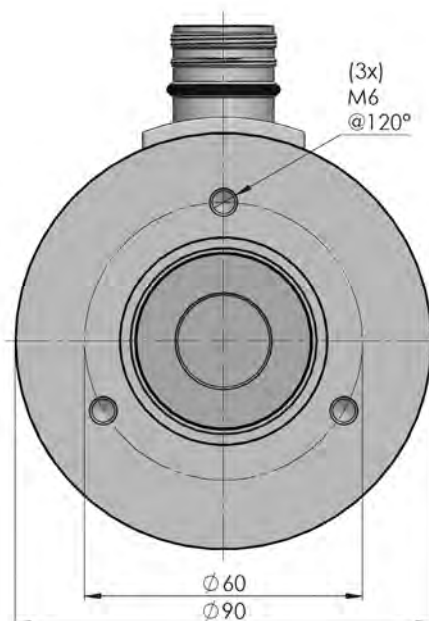
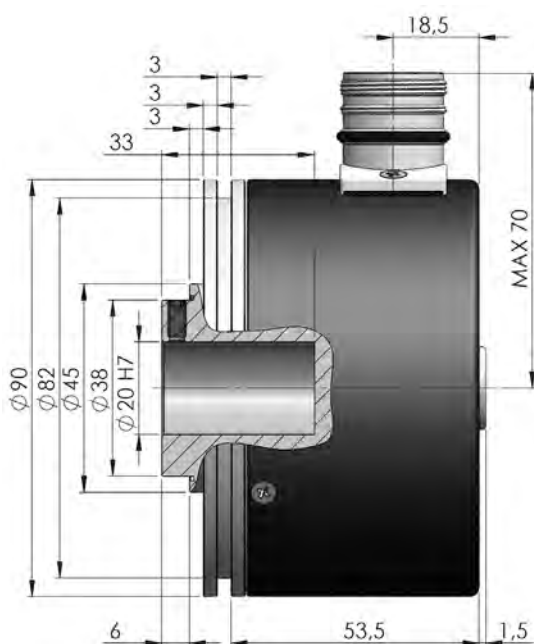

All specification in millimeters

### Output circuits

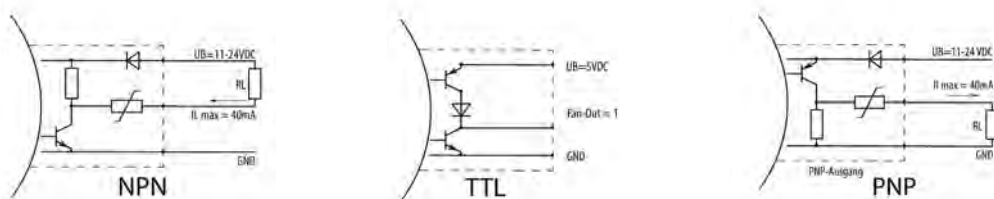

### Output code

Output code	Resolution	Inputs	Option
Binär, BCD	2, 4, 8, 16, 32, 64, 128, 256, 512, 1.024, 2.048	(Optocoupler) Counting direction switchover with + U <sub>B</sub>	Latch (Optocoupler input, control with + U <sub>B</sub> )
Gray (beginning bei 0)	2, 4, 8, 16, 32, 64, 128, 256, 512, 1.024, 2.048, 4.096		
Gray-Excess (beginning ≠ 0)	45, 90, 180, 360, 720, 1.440, 2.880, 3.600		

### Pin configuration

Connection type	BCD*		10 <sub>0</sub>				10 <sub>1</sub>				10 <sub>2</sub>				10 <sub>3</sub>				Option	↔
	GND	+ U <sub>B</sub>	1	2	4	8	1	2	4	8	1	2	4	8	1	2	4			
12	1	2	3	4	5	6	7	8	9	10	11	12	-	-	-	-	-	-	-	
16	1	2	3	4	5	6	7	8	9	10	11	12	13	14	15	16	-	-	-	
00	white	brown	green	yellow	gray	pink	blue	red	black	purple	gr/pin	bl/re	ws/gre	br/gre	ws/ye	ye/br	ws/gr	gr/br	ws/pin	

\* as of resolution 2048 BCD, only cable output!

### Order reference

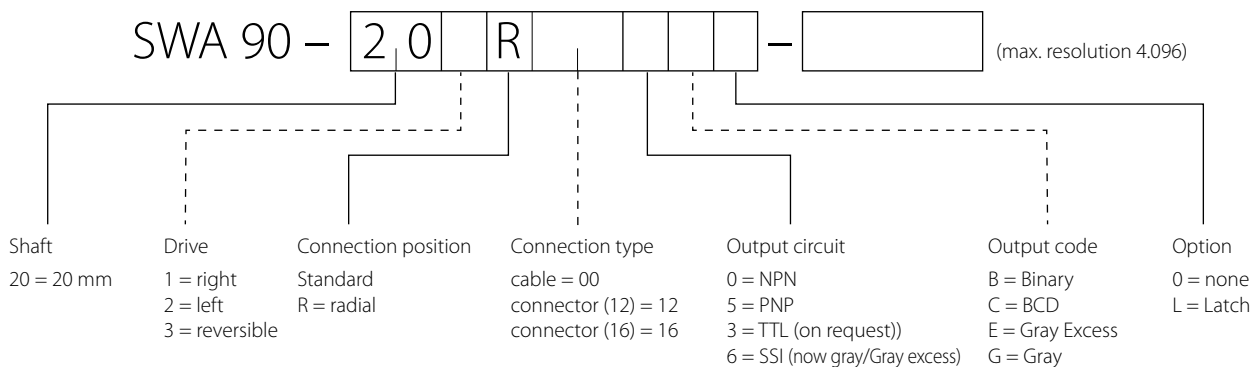

# Series AWA 70 Ex & HWA 70 Ex



## Series AWA 70 Ex & HWA 70 Ex

- ▶ Absolute Ex-rotary-encoder with 10, 12 or 14 mm solid- or blind hollow shaft and SSI interface
- ▶ Housing diameter 70 mm for design type "Pressurised encapsulation" and high degree of protection
- ▶ With Ex d IIC T6 (PTB 09 ATEX 1106 X)
- ▶ Maximum resolution 13 Bit
- ▶ Short-circuit-proof outputs
- ▶ Overvoltage and reverse polarity protection on the operating voltage input (at  $U_b = 10\text{-}30\text{V DC}$ )
- ▶ Accessories from page 78

### Mechanical specifications

Speed:	max. 6.000 U/min.	Working temperature range:	$-40^{\circ}\text{C} \dots +60^{\circ}\text{C}$
Moment of inertia of the rotor:	ca. $4 \times 10^{-6} \text{ kgm}^2$	Shaft:	Stainless steel
perm. shaft load radial:	80 N (at shaft end)	Shock resistance according to	
perm. shaft load axial:	20 N	EN 600068-2-27:	2.500+ $\text{m/s}^2$ , 6 ms
Starting torque (25° C):	< 0,05 Nm	Vibration resistance according to	
Weight:	ca. 1,5 kg	EN 600068-2-6:	100 $\text{m/s}^2$ , 55 ... 2.000 Hz
Protection class according to EN 60 529:	IP 67		

### Electrical specifications

Interface type	Synchronous - Serial (SSI)	Synchronous - Serial (SSI)
Supply voltage ( $U_b$ )	5 V DC (+/- 5%)	10 - 30 V DC
Output driver	RS 485	RS 485
Current consumption type	89 mA	89 mA
Current consumption max.	138 mA	138 mA
Perm. load/channel	max. +/- 20 mA	max. +/- 20 mA
Cycle rate min./max.	max. 15.000/s	max. 15.000/s
Taktrate, min. / max.	100 kHz / 500 kHz	100 kHz / 500 kHz
Short-circuit-proof outputs <sup>1)</sup>	yes	yes <sup>2)</sup>
Reverse polarity protection on $U_b$	no	yes

<sup>1)</sup> With correctly applied supply voltage  $U_b$

<sup>2)</sup> Only one channel at the same time: with  $U_b = 5\text{V}$  short circuit to channel and 0V and +  $U_b$  is permissible  
with  $U_b = 10\text{-}30\text{V}$  short circuit to channel and 0V is permissible



## Mechanical dimensions

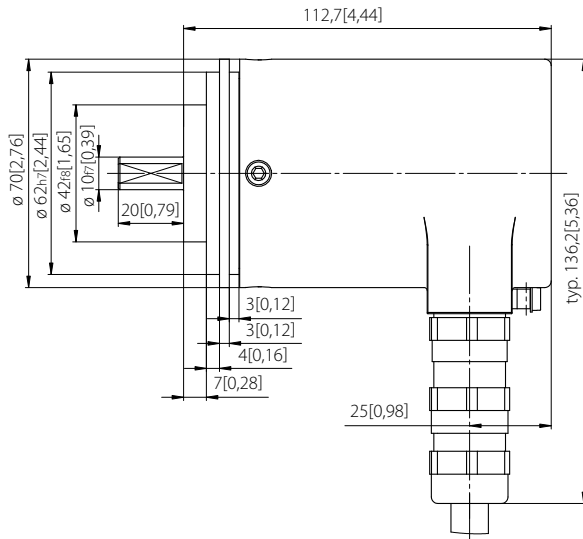
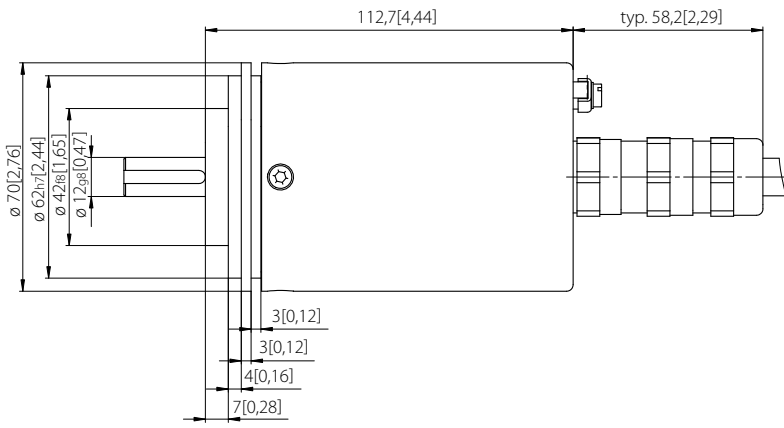

# Series AWA 70 Ex & HWA 70 Ex

## Mechanical dimensions

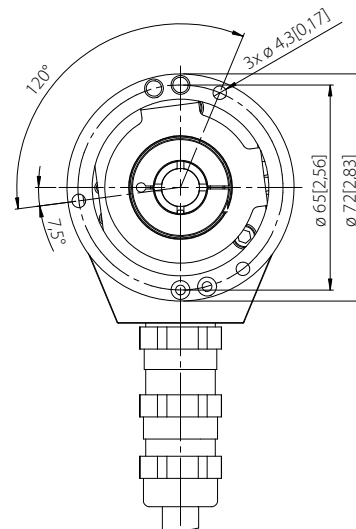
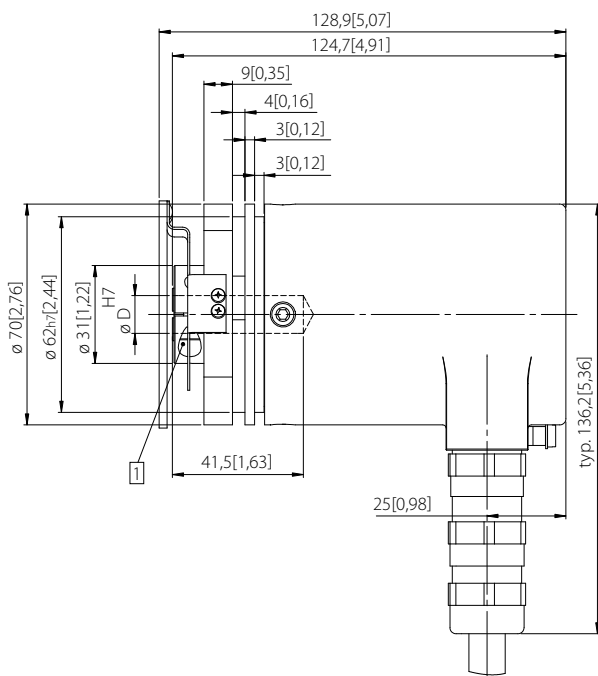
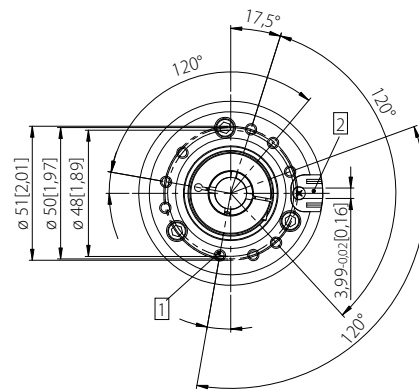
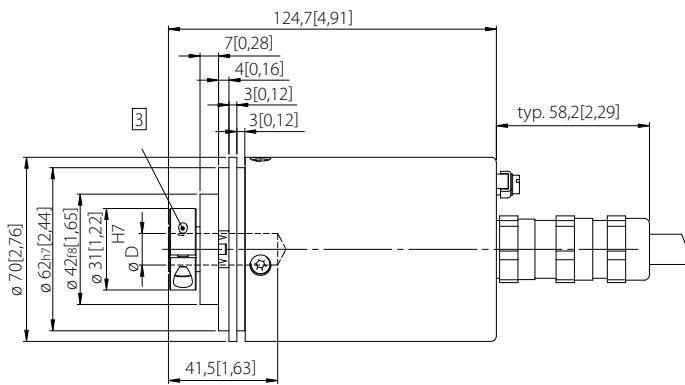

### Installation instructions

Flange and shaft of encoder and drive may not be rigidly coupled at the same time!

### Please observe

All current standards for installing electrical systems in potentially explosive atmospheres must be observed during installation! Manipulations of the encoder (opening, mechanical processing) will lead to the loss of ex approval and guarantees! The installer assumes the consequential liability!

### Counting direction

Ascending code values during clockwise rotation of shaft. (facing the shaft)

### Max. permissible transfer rate for SSI

depending on the cable length

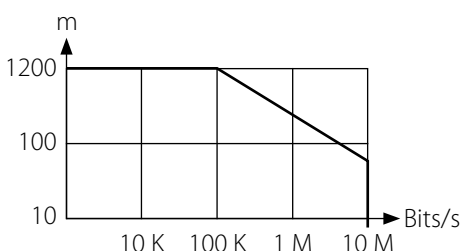

### SSI interface

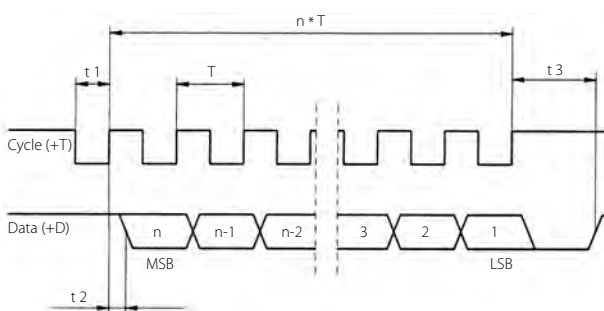

### Functional description of the SSI interface

The cycle and data lines are at high level when in idle state. The first decreasing clock pulse edge signals the start of data transfer. The clock pulse edges increasing thereafter, transfer the data bit by bit, starting with MSB. The transfer of a complete data word requires n+1 increasing clock pulse edges (n=resolution in bit). The data line remains on low after the last positive clock pulse edge, until the encoder is ready again for a new data word. The cycle line must remain at least as long on high, and can subsequently start once again a new read-out sequence of the encoder with a decreasing edge.

**Please observe!** The data update is carried out synchronously with the read-out cycle. The data are thus as current as the time lag between two read-outs; a periodic read-out of the encoder is, therefore, recommended. After a longer read-out interval and simultaneous shaft rotation of the encoder, the data content of the first read-out can be "outdated" and should be ignored.

### Pin configuration

Signal	0V	+V	C+	C-	D+	D-	SET	DIR	Stat	⊥	⊥
Cable labelling	1	2	3	4	5	6	7	8	9	YE/GN	Shield

### Order reference

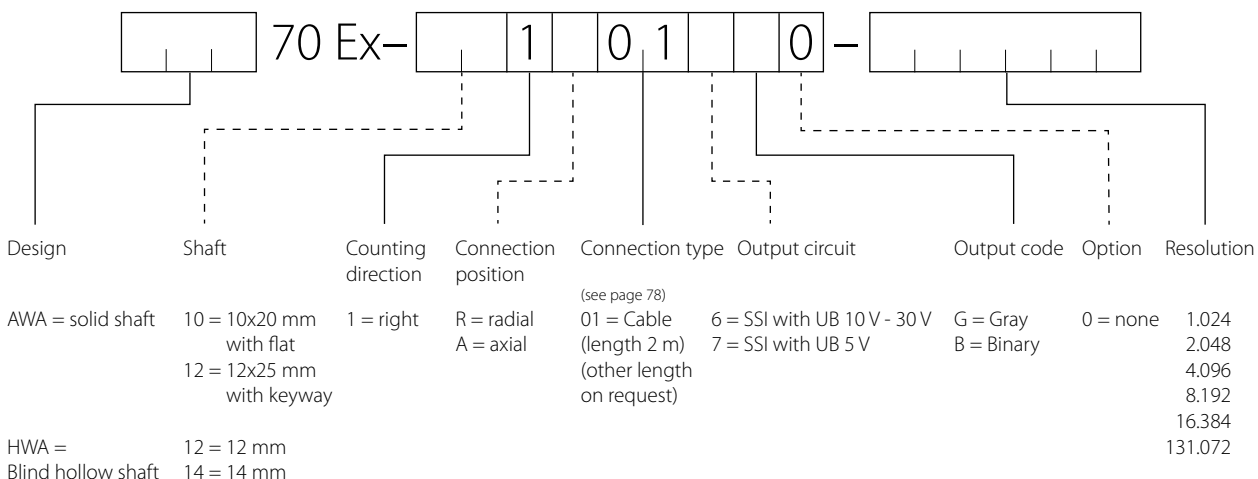

# Draw Wire Series EM

## Draw Wire Series EM

- ▶ Draw wire for incremental and absolute rotary-encoders
- ▶ 4 m, 8m or 10 m length
- ▶ Accessories from page 78

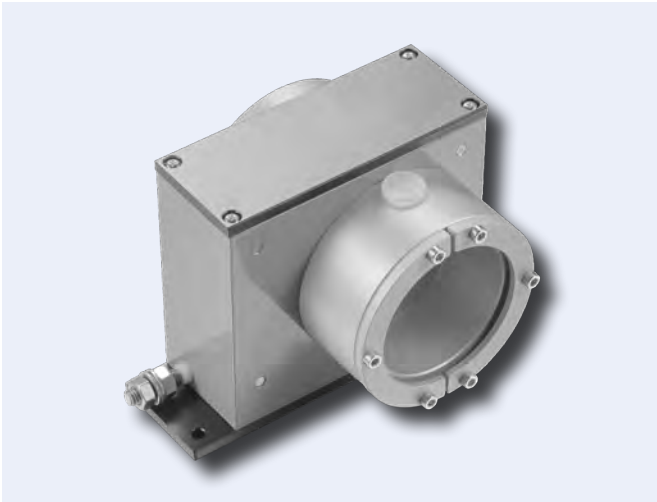

The ENCO-METER enables simple, quick and cost-effective adaptation of the rational signal recorders (encoder, potentiometer ...) to measure linear distances of up to 10 metres on slow moving machines without abrupt accelerations and with an average number of switching operations.

It consists of a stainless steel micro-cable with which its free end must be connected to the moveable component of the machine.

The other end of the cable is rolled up in a precision drum inside the device while a leaf spring always keeps it tensioned. The drum shaft can actuate any type of rotary/signal recorders.

By default, we have potentiometers with  $R = 10 \text{ k}\Omega$  and  $n = 10$  rotations in stock. It should be noted that the mechanical route of the potentiometer may restrict the measuring range of the ENCO-METER.

### Output devices

Upon request, we can deliver the ENCO-METER already mounted to an electronic output device, such as an incremental encoder, absolute encoder or potentiometer. If a specific resolution  $r$  (mm per pulse) is wanted in case of an absolute or incremental encoder, the number of pulses of the encoder ( $n$ ) is calculated as follows:

$$n = \frac{D}{r} \quad (D \text{ is the unrolling of the ENCO-METER in mm})$$

### Installation

The ENCO-METERS are mounted on a flat surface of the machine by means of 3 or 4 screws M4. Any mounting position may be used. The cable must be properly aligned ( $\alpha < 2^\circ$ ) and may, under no circumstances, exceed the measuring range. Using a potentiometer results in an output ratio  $r$  (in  $\Omega$  per mm) according to:

$$r = \frac{R}{D \times n} \quad (R \text{ is the nominal resistance and } n \text{ the number of rotations})$$

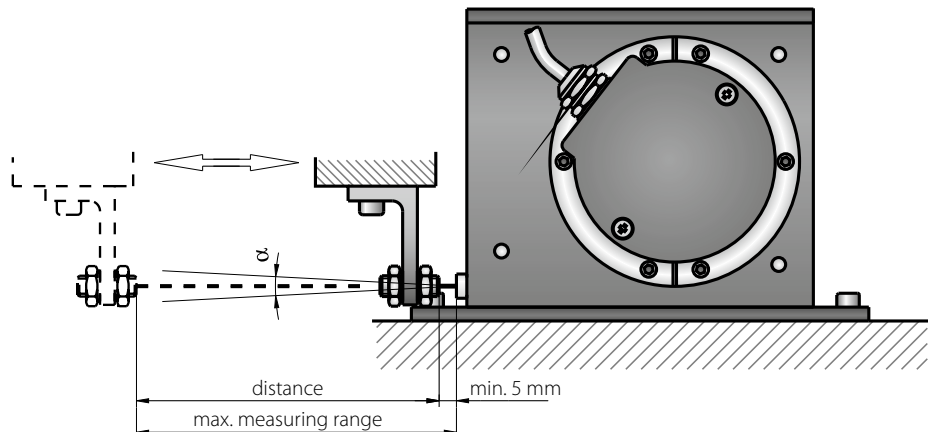

Technical data

Modell	EM4	EM8	EM10
Unrolling	200 mm <sup>(1)</sup>	250 mm <sup>(1)</sup>	300 mm <sup>(1)</sup>
Reference	90.1404	90.1808	90.1810
Cable <sup>(2)</sup>	Ø 0,61 made of stainless steel AISI316 (structure 19 x 7 + 0)		
Measuring range	up to 4.000 mm	up to 8.000 mm	up to 10.000 mm
Maximum extent of the cable	4.010 mm	8.010 mm	10.010 mm
Static minimum tension of the cable	3 N	6 N	6 N
Static maximum tension of the cable	8.9 N	13N	13 N
Max. extension acceleration	35 m/s <sup>2</sup>	30 m/s <sup>2</sup>	25 m/s <sup>2</sup>
Max. recovery acceleration <sup>(3)</sup>	10 m/s <sup>2</sup>	12 m/s <sup>2</sup>	12 m/s <sup>2</sup>
Max. speed	1 m/s	0.75 m/s	0.75 m/s
Dust and splash protection	IP51 according to DIN 40050		

<sup>(1)</sup> ±0.06 mm per revolution

<sup>(2)</sup> Other types of cables are available upon request.

<sup>(3)</sup> We can deliver EM4s with dual drive torque allowing a doubling of the recovery accelerations.

Mechanical dimensions

EM 4

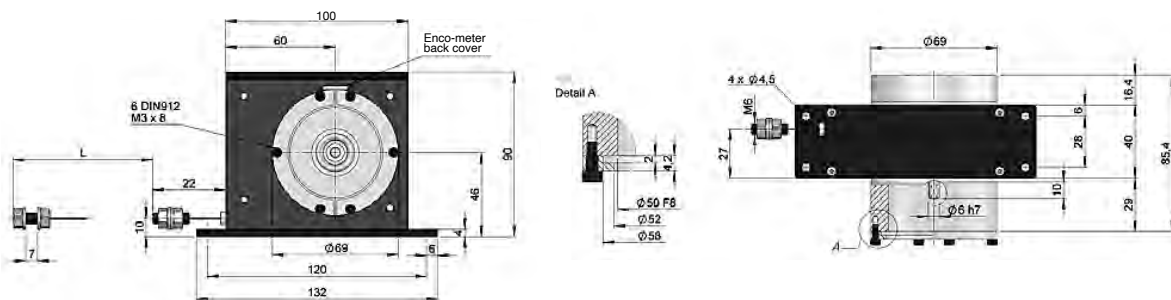

EM 8

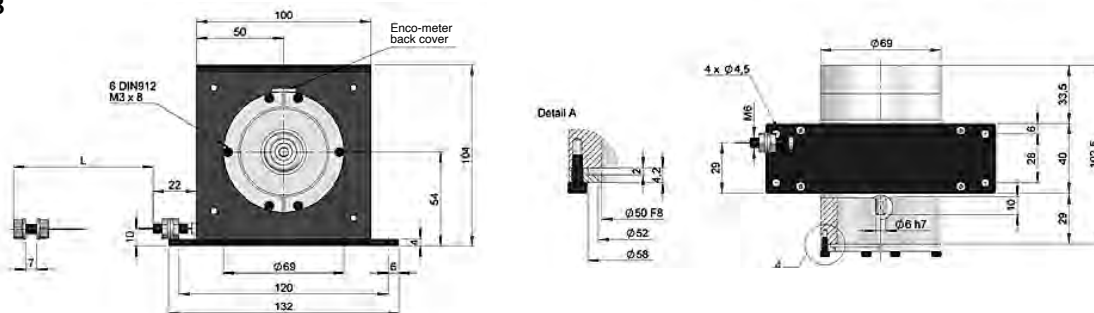



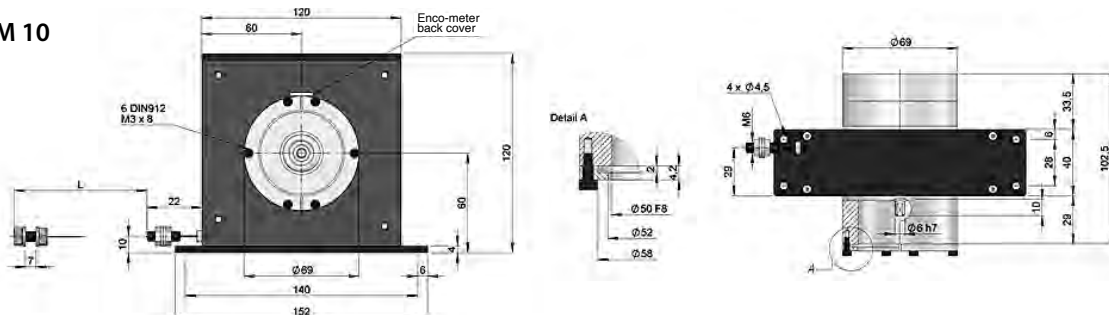





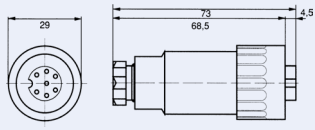

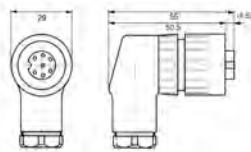

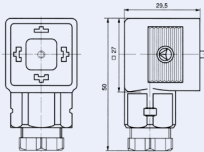

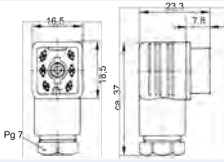
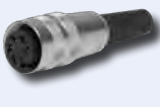
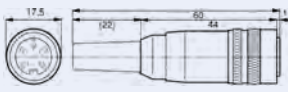
EM 10

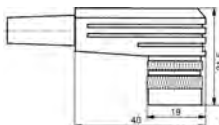

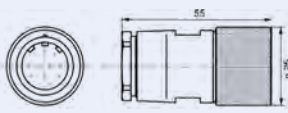
# Accessories

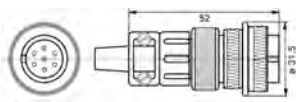
## Connection types

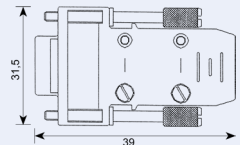
No.	Illustration	Dimensions			
00	Cable connection (IP 65)	Standard:	2 m	AWI 40: 3 m	Colour code according to DIN 47100
01	Cable connection (IP 65)	Standard:	2 m	AWI 40: 3 m	
B, F	Cable connection (IP 65)	Standard:	1,5 m		
02	 IP 65	Material:	Plastic		
		Pole number:	6 + E		
		Total length:	77 mm		
					
03	 IP 65	Material:	Plastic		
		Pole number:	6 + E		
		Total length:	60 mm		
					
05	 IP 65	Material:	Plastic		
		Pole number:	3 + E		
		Total length:	40 mm		
					
07	 IP 65	Material:	Plastic		
		Pole number:	6		
		Total length:	33 mm		
					
08, 10	 IP 40	Material:	Brass		
		Pole number:	5 / 6		Please observe! When selecting this connection type, the degree of protection reduces to IP 40.
		Total length:	62 mm		
					
09, 11	 IP 40	Material:	Brass		
		Pole number:	5 / 6		Please observe! When selecting this connection type, the degree of protection reduces to IP 40.
		Total length:	34 mm		
					
12, 16, 17, D, H, I, Y	 IP 65	Material:	Brass		
		Pole number:	12/16/17		D = 12-pole clockwise H = 12-pole anticlockwise I = 9-pole clockwise Y = 17-pole clockwise
		Total length:	60 mm		
					
52	 IP 65	Material:	Aluminium		
		Pole number:	7 / 10		
		Total length:	52 mm		
					
54	 IP 40	Material:	Plastic		
		Pole number:	9 / 25		Please observe! When selecting this connection type, the degree of protection reduces to IP 40.
		Total length:	ca. 50 mm		
					

Torque supports



Mechanical dimensions

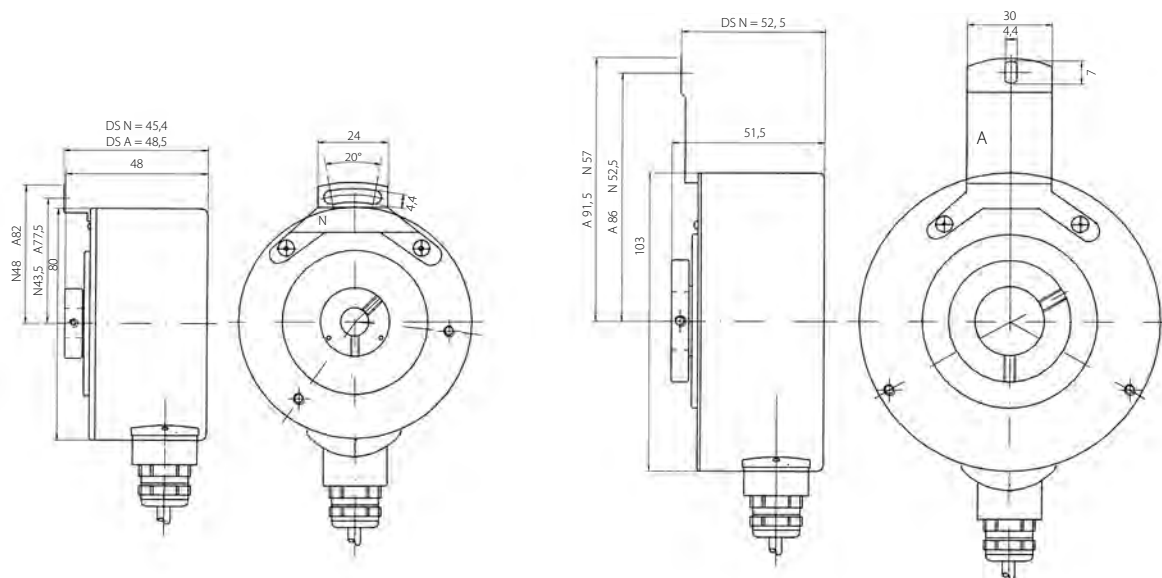











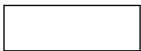

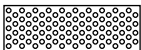

Installation instructions

In order to compensate axial and radial shaft run-out, as well as any angle set, the rotary encoder flange may not be rigidly secured. Fix the flange above a stator coupling (e.g. spring sheet) as torque support.

The following flexible fixing plates are available:

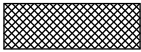
- |      |                                   |  |
|------|-----------------------------------|--|
| DS A | suitable for encoder type HWI 103 | Shaft offset max: +/- 2.0 mm axial, +/- 0.15 mm radial |
| DS N | suitable for encoder type HWI 80  | Shaft offset max: +/- 0.5 mm axial, +/- 0.3 mm radial  |

# Accessories

Measuring wheels	Type	Circumference	Material	D	B	Coating	Profile
	M 101	500	Plastic or Aluminium	10 / 12	25	Smooth plastic	
	M 102	500	Plastic or Aluminium	10 / 12	25	Ribbed plastic	
	M 120	500	Plastic or Aluminium	10 / 12	25	Napped rubber	
	M 130	500	Plastic or Aluminium	10 / 12	25	Knurled aluminium	
	M 140	500	Plastic or Aluminium	10 / 12	25	Vulkollan plastic	
	M 108	200	Plastic or Aluminium	6/10	12	Smooth plastic	
	M 110	200	Plastic or Aluminium	6/10	12	Knurled aluminium	
	M 190	200	Plastic or Aluminium	6/10	12	Napped rubber	
	M 109	200	Plastic or Aluminium	6/10	12	Ribbed plastic	

## Mechanical dimensions





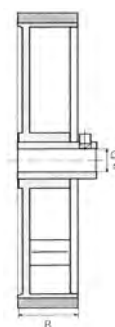
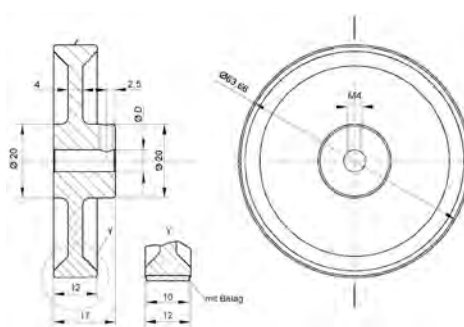
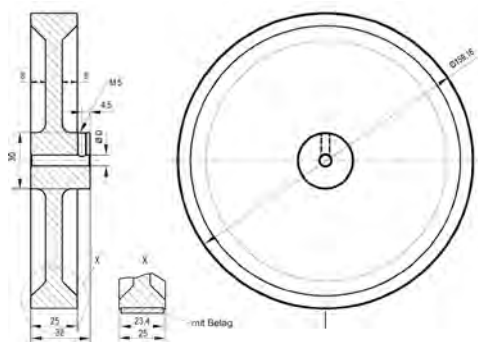

Measuring wheel 500 mm circumference

Measuring wheel 200 mm circumference

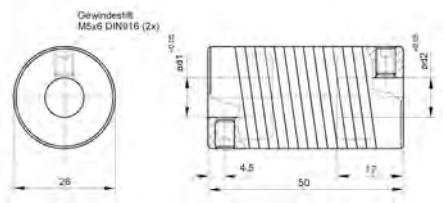
Tolerance  
0.2 % – 0.5 %

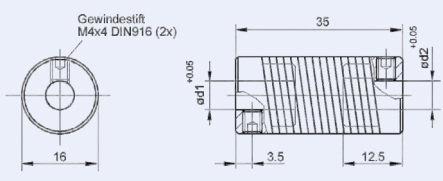

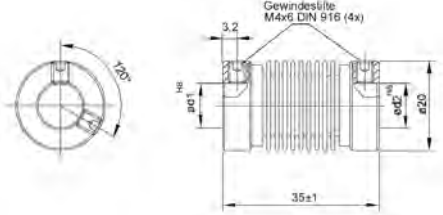

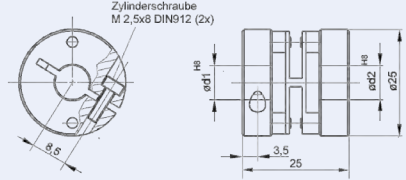
Couplings	Type	A	B	d <sup>1</sup>	d <sup>2</sup>	Mechanical dimensions
	Spring coupling K 401	50	26	6	6	
				6	8	
				6	10	
				8	8	
				8	10	
				10	10	
				10	12	
		12	12			
	Spring coupling K 402	35	16	4	5	
				5	5	
				5	6	
				6	6	
				6	8	
				6	8	
				8	8	
	Bellows coupling K 409	35	20	4	4	
				4	6	
				6	6	
				6	10	
				8	8	
				10	10	
				10	12	
	Spring washer coupling K 410	25	25	6	6	
				6	10	
				8	8	
				10	10	
				10	12	
				10	12	
				12	12	

Rack	Type	Width	Height	Length
	Z 214	5	20	1000

Sprocket	Type	Teeth	Circumference
	R 218	16	50,26

# Accessories

## Round flange

**F 2** for series AWI 58, AWI 58H, AWA 58, BC 58, PS and PSM

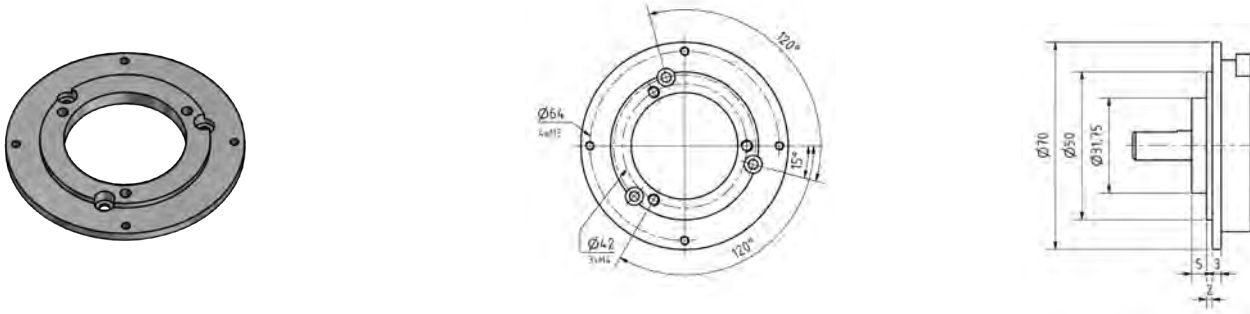

## Round flange

**F 3** for series AWI 58, AWI 58H, AWA 58, BC 58, PS and PSM

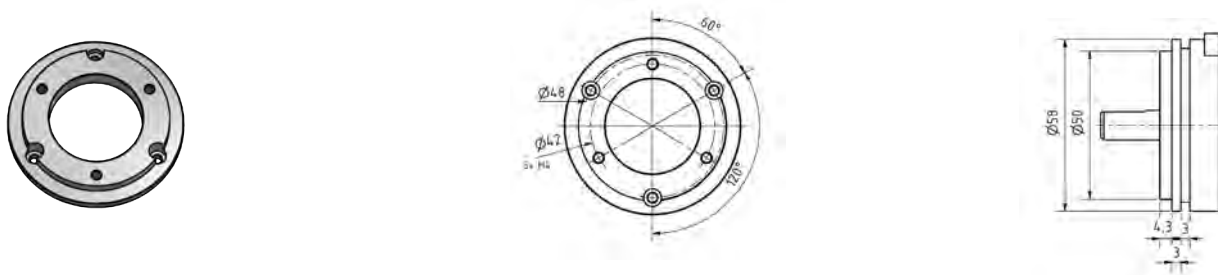

## Round flange

**F 4** for series AWI 58, AWI 58H, AWA 58, BC 58, PS and PSM

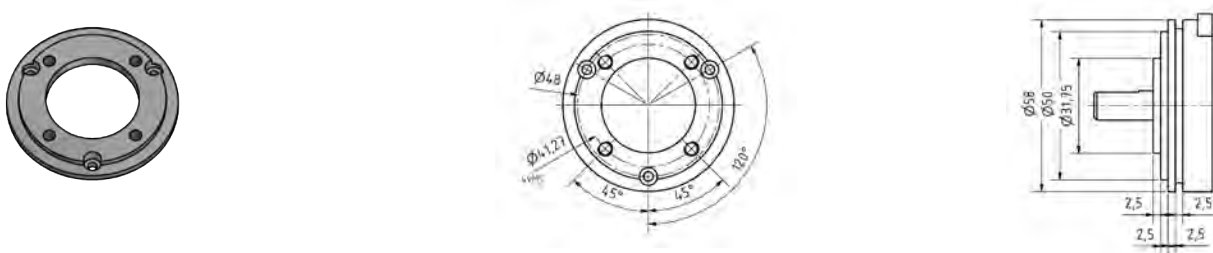

## Round flange

**Euro flange** for series AWI 58, AWI 58H, AWA 58, BC 58, PS and PSM, AWI 90, AWA 90, PA 02, PH 05, 70-140 and 72

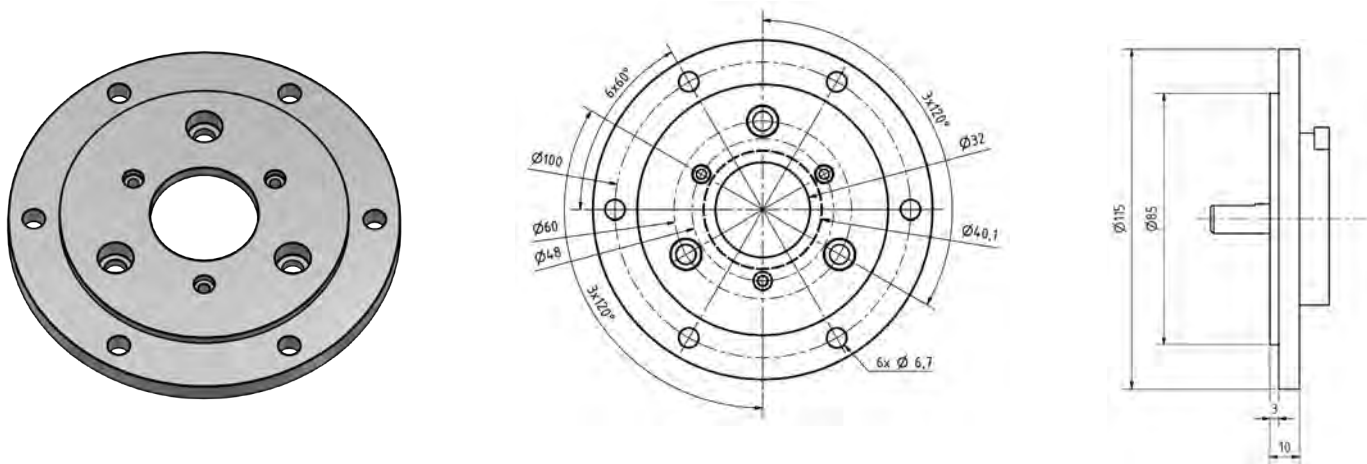

Square flange

F 5 for series AWI 58, AWI 58H, AWA 58, BC 58, PS and PSM

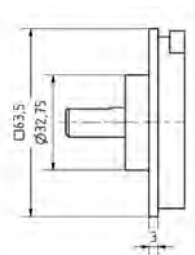
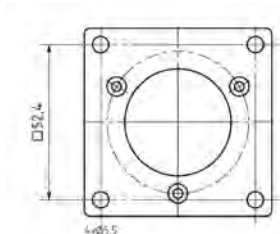
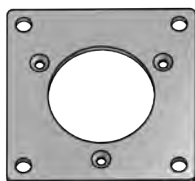

Square flange

F 6 for series AWI 58, AWI 58H, AWA 58, BC 58, PS and PSM

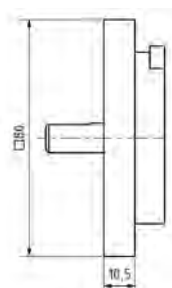
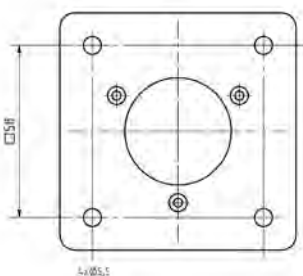
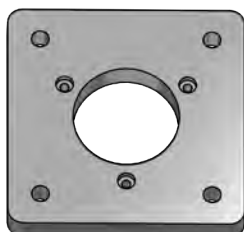

Square flange

F 7 S for series AWI 40 S

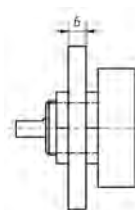
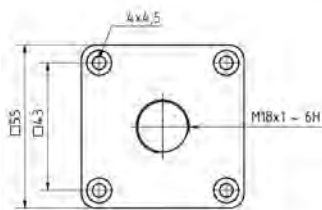

Square flange

F 7 E for series AWI 40 E

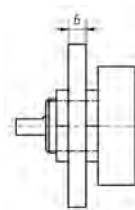
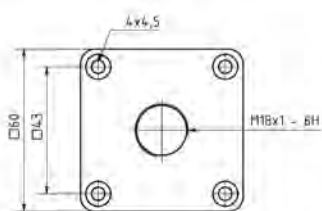

# Accessories

## Angle flange

**WF 1** for series AWI 90, AWA 90, PH 05, PA 02, 72, 70-140

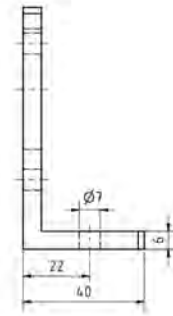
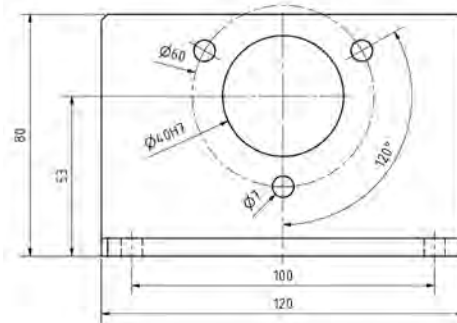
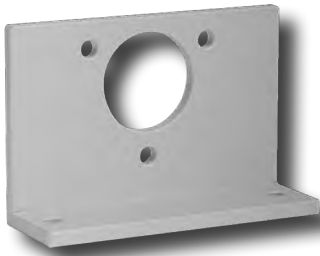

## Angle flange

**WF 2** for series AWI 58, AWI 58H, AWA 58, BC 58, PS and PSM

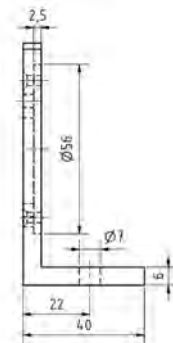
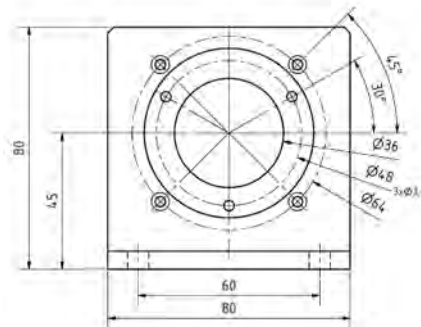
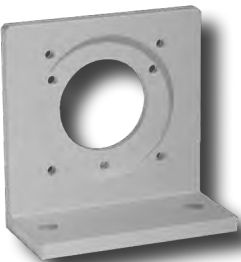

## Angle flange

**WF 3** for series AWI 58, AWI 58H, AWA 58, BC 58, PS and PSM

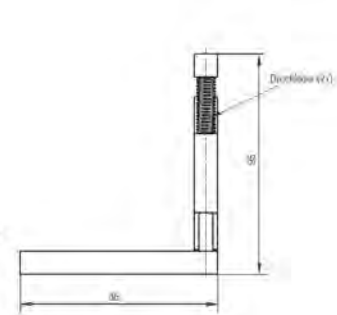
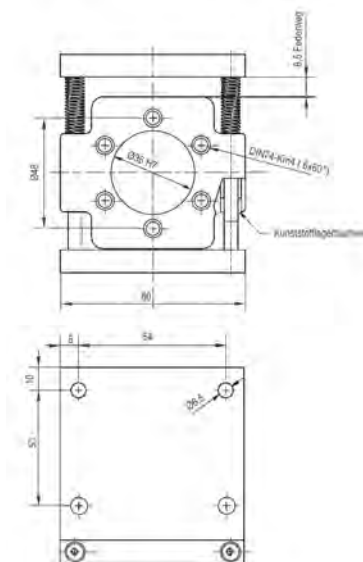
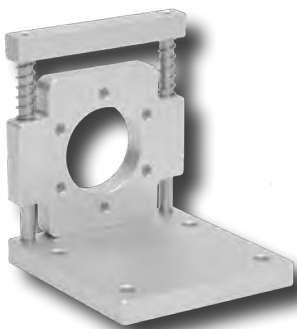



## Mounting bell

For series AWA 58, AWI 58, AWI 58 H,  
BC 58, PS & PSM

The mounting bell MOGL 5038 provides a very simple and inexpensive installation for all encoders with a synchro flange. The mounting bell made of fibreglass-reinforced plastic in injection moulding technology has a thermally and electrically insulating effect.

The encoder is mounted optionally onto the bell with 3 screws M4 x 10 DIN 912 or 3 mounting eccentrics

### Technical data

#### Model

Material  
Temperature range  
Weight  
Net distance (encoder drive)  
Net outlet (for coupling)

#### MOGL 5038

Fortron (PPS) 40% fibreglass-reinforced, black  
-40° C ... +270°C  
54 g  
25.8 mm  
Ø 32.1 mm

### Mechanical dimensions

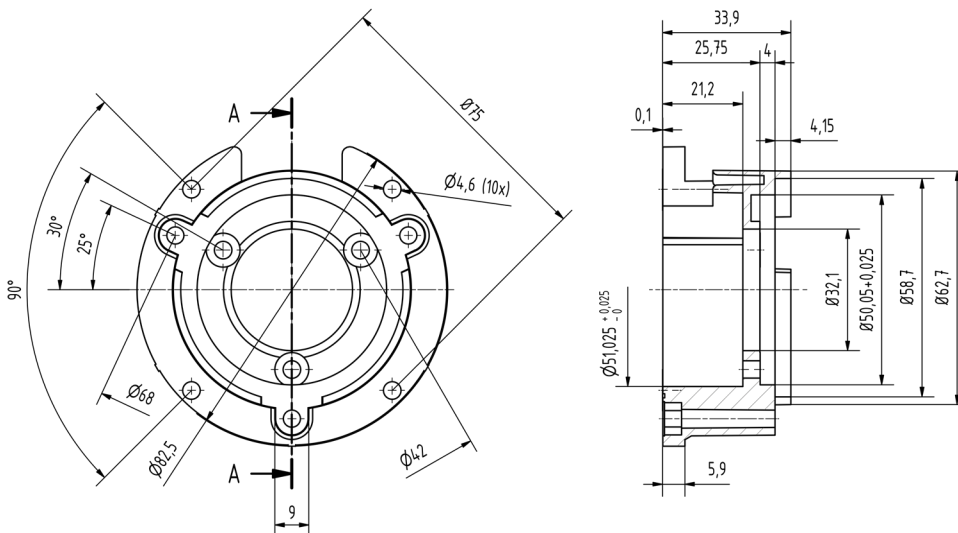

### Mounting kit DMSA 2000 for mounting bell

consisting of:

- 4 x screw M4 x 12 DIN 912
- 3 x mounting eccentric BEMN 1242 49
- 3 x screw M4 x 10 DIN 912
- 3 x cylinder screw M4 x 35 DIN 84 A2
- 7 x disc 4.3 DIN 433
- 3 x hexagon nut M4 DIN 934 A2

# Assembly and Installation Instructions

## Assembly and installation instructions

Hohner rotary encoders can be used both in simple industrial applications, as well as toughest environmental conditions, depending on the type and design.

The precision and optoelectronic components used in an incremental or absolute encoder today no longer present a problem regarding the above-mentioned applications. However, in order to ensure proper functioning of your rotary encoder, the following assembly and installation instructions should be observed:

### Electrical:

- ▶ When wiring or pulling the plug, it is essential to ensure absence of voltage.
- ▶ Static discharges at the connections may cause damage.
- ▶ The shielded cable must be connected to the PE in the control cabinet (the shield is not connected in the device, i.e. unilateral shielding).
- ▶ Unused cables should be connected on a floating basis isolated from each other.
- ▶ Do not lay the encoder cable parallel or near the load lines.
- ▶ The tests carried out according to the certificate of conformity were performed in the standard version with 2 m cable.

### Mechanical:

- ▶ It is imperative to avoid blows to the shaft.
- ▶ The maximum shaft load may not be exceeded.
- ▶ An axial or radial shaft misalignment must be compensated through suitable measures, such as through the use of couplings, torque supports, belt drive, or similar.
- ▶ The device may not be mechanically modified.
- ▶ When using hollow shaft encoders, a distortion-free installation should be ensured.

These are just some instructions for which observance thereof can avoid problems during the application of encoders. Should any questions arise during the assembly or installation of Hohner rotary encoders, our expert staff will be at your disposal with advice and practical support.

# Declaration of conformity

## EC declaration of Conformity

Hohner Elektrotechnik GmbH  
Gewerbehof 1  
D – 59368 Werne

In compliance with the standard 2014/30/EU which states the Electromagnetic Compatibility and 2014/35/EU which states the Electrical Safety, guarantees that the products of series:

20, AWI40 with "C", AWI58, AWI58H, PR90, PMS, AWI90, AWI90 Redundant, PH05, PA02, 27, 21, 24, 28, 29, H, HC, 66, TR, HWI40, HWI58, SWI58, PR90H, HWI80, HWI103, MIG Nova+, 25, PEH, PT, BS, BSP, BSC, PR, PL, RI76TD, PM, PK, AWA58, BC58, PS, PSM, AWA90, 70-140, 72, R, S, SM, SS, SSM, MS, MM, TS, TM, SWA90, HWA103, AS, ASP, ASC, MAS, SAS, SAM, PRA, PZL, HP, HPC, HPH, 3000, 55, 08, NAMFPX, 14, MXE, CS30, CSRXE, CSMXE, AWI70Ex, HWI70Ex, AWA70Ex, HWA70Ex, E, NAMYQX, W, IP300, 85, RXE, RXL, MXL, CMMXE, DLS-001, PTS-001, CHM-001, SUBCWD, INHO,

meet the requirements:

2014/30/EU	Electromagnetic Compatibility
2014/35/EU	Electrical Safety

according to the relevant standard below mentioned:

EN-61000-6-2:2006-03	Generic Standards – Immunity for industrial environments
EN-61000-6-4:2011-09	Generic Standards – Emission standard for industrial environments
EN-55011:2011-04	Conducted and radiated emissions
EN-61000-4-2:2009-12	Immunity to Electrostatic Discharges
EN-61000-4-3:2011-04	Immunity to RF radiated fields
EN-61000-4-4:2013-04	Immunity to Electrical fast transient / Burst
EN-61000-4-5:2015-03	Immunity to surges
EN-61000-4-6:2014-08	Immunity to conducted RF disturbances
EN-61000-4-8:2010-11	Immunity to Power-Frequency Magnetic Fields
EN-61000-4-11:2005-02	Voltage dips and interruptions
EN-60079-0:2014-06	Potentially explosive atmospheres - Part 0 resources - General requirements
EN-60079-1:2015-04	Potentially explosive atmospheres - Part 1 Equipment protection by flameproof enclosure "d"
EN-61241-0:2014-06	Potentially explosive atmospheres - Part 0 resources - General requirements
EN-61241-1:2014-12	Potentially explosive atmospheres - Part 31 device dust ignition protection by enclosure "t"

According to 2014/95/EU Directive the products are supplied with CE mark on the products themselves to state the conformity with Standard Requirements.

Werne, the 01.08.2016

Hohner Elektrotechnik GmbH  
Burkhard Jankowski, General Manager





# General sales conditions

## General sales conditions no. 4

### General

The following general sales conditions apply exclusively to all transactions between us and our business partners, even if different conditions are stipulated or prescribed to us. All orders placed by travelling staff or representatives require our written consent to be valid.

### Prices

The prices are deemed ex works, strictly net, without packaging costs and the like; they are always subject to change.

### Delivery time

Any agreed dates and periods are always considered as estimates. We reserve the right to withdraw from the contract should circumstances arise changing the conditions existing at the time of the offer, order or order confirmation. For such cases, we have, at our own discretion, the right to adhere to the contract and charge the current price for the goods valid at the time of delivery.

### Shipment

Shipment always takes place, even with post-paid deliveries, at the expense and risk of the buyer. Insurance for damages in transit is made at the request and expense of the buyer. However, we reserve the right to insure the shipment in whole or part at the expense of the buyer, without obligation to do so. For reports of damage to shipments insured through us, the terms and deadlines of the respective carrier and insurance companies apply.

### Packaging

The packaging of the goods is, unless otherwise agreed, determined at our discretion. We reserve the right to charge, besides the value calculation, a deposit for special packaging. Packaging is charged at cost price and will not be taken back.

### Payment

Place of performance for deliveries and payment is for all current and future orders Werne. Payments shall be made, unless otherwise agreed, net 30 days after the invoice date, without any deduction free of charge to Werne. The date of settlement is the date upon which the amount is at our disposal. For payments within 8 days after the invoice date, we grant a 2% cash discount. In the case of delayed payment, a 3% default interest will be charged above the legal bank discount, while reserving the right to assert claims for higher compensation.

Upon deterioration of the buyer's ability to pay or after receiving unfavourable information about him, we have the right to demand advance payment of sufficient security of the invoice amounts, even if other conditions are provided or agreed upon. In these cases, unpaid bills are payable immediately. The same applies if the buyer mortgages stocks, accounts receivables, etc. or purchases goods as security for other creditors, or fails to pay despite repeated reminders. Retention or offset with any claims by the buyer against our payment entitlement is excluded.

### Reservation of title

The delivered goods remain our property until the purchase price is paid in full and until payment of all previous and future deliveries within the business relations, including all secondary claims (if payment is made by a bill of exchange, until the discharge of the check or bill). The buyer is hitherto not entitled to pledge the goods to third parties or transfer them by way of security. The ruling rights of sale during the ordinary course of business remains unaffected. In the event of resale, it is agreed that the reservation of title to the resold goods are forwarded from the buyer to the new buyer or new seller. The proceeds from the resale should be kept separately in our behalf. The buyer herewith assigns all claims against a third party resulting from the resale or any other legal reason to us for our security. The buyer is authorised to collect these claims on our account as long as the buyer meets his payment obligations to us in due course. We are, however, entitled to inform the buyer (third party), to be identified upon request, of the transferral of the claim, and issue instructions. The buyer must inform us immediately of any access by third parties to the goods supplied under reservation of title or assigned claims. The right of title is also valid against the carrier to whom the goods are handed over at the request of the buyer or on our commission.

### Custom-made products

For custom-made products, we have the right to demand total or partial advance payment. For mass-produced articles we are entitled to carry out excess or short deliveries of 20% and partial deliveries.

Tools always remain our property, even if the buyer has paid them in whole or part.

It is exclusively up to the buyer to ensure that the goods commissioned do not violate the property right of third parties. The buyer thereby assumes full responsibility for any claim towards us.

### Complaints

Complaints must be reported to us in writing immediately after discovery. Should we not receive a specified notice of defects by the buyer within 4 weeks after

receipt of the goods at the address location, namely at the postal, or railway station, or receiving forwarded, or air freight, sea port agency, etc. of the address location, quality and quantity, etc. are deemed to be approved under relinquishment of any right to complaint relating to apparent or allegedly concealed defects. For any goods delivered by us proving to be defective, after unchanged receipt of goods free of charge, provided timely and formally correct submission of the complaint, we may, at our discretion, provide either free replacement, or repair, or refund the value of the goods at the current price at the time of receipt by us. Any further claims of the buyer or third party are expressly excluded in any case.

Tolerance ranges shall be deemed as accepted according to the respective state of the art technology, unless special agreements have been explicitly agreed.

### Warranty terms

Regarding deficiencies of the delivery, including the absence of expressly warranted characteristics, we shall be liable in such a way that we will repair or replace at our discretion all parts which prove useless or considerably impaired in their usefulness, within 6 months (3 months for shift operations) since the delivery date (day we dispatched). We shall only be liable for material defects where reasonable care should have led us to recognise the defects. Any further claims of any kind of the buyer or third party are expressly excluded in any case. The buyer shall bear any costs incurred by us arising from unjustified notices of defect.

We must be notified in writing of any complaints immediately after discovery and concerned parts should be submitted upon request. The complaint period ends at the latest upon expiry of the 7th month since the day of delivery (day we dispatched).

The buyer shall afford us the necessary time and opportunity to undertake all the changes deemed necessary to supply spare parts. Replaced delivery items shall become our property.

No liability shall be assumed: a) for damage resulting from normal wear; b) as long as the buyer has not fulfilled his obligations towards us, especially the agreed conditions of payment; c) when the buyer carries out modifications and repairs without our authorisation.

Tolerance ranges shall be deemed as accepted according to the respective state of the art technology, unless special agreements have been explicitly agreed.

We have carefully checked all the information in this catalogue (technical data, illustrations, dimensions, etc.) and they are based on our knowledge and production status at the time of printing. They do not, however, represent binding assurance.

### Place of jurisdiction

The relationship between us and our clients is governed by German law. Place of jurisdiction for everything arising from the delivery contract

### Hohner Elektrotechnik GmbH

Gewerbehof 1  
D - 59368 Werne

Phone: 0049 (0) 2389 9878-14

Fax.: 0049 (0) 2389 9878-28

E-Mail: [info@hohner-elektrotechnik.de](mailto:info@hohner-elektrotechnik.de)

Homepage: [www.hohner-elektrotechnik.de](http://www.hohner-elektrotechnik.de)





# Notes

Lined area for notes.





# **hohner**

---

Elektrotechnik Werne

**Hohner Elektrotechnik GmbH**

Gewerbehof 1 · D-59368 Werne

Phone +49 - 2389 - 9878-0 · Fax +49 - 2389 - 9878-27

info@hohner-elektrotechnik.de · [www.hohner-elektrotechnik.de](http://www.hohner-elektrotechnik.de)