

SERIE PR90H

PROGRAMMABLE INCREMENTAL HOLLOW SHAFT ENCODER FOR INDUSTRIAL APPLICATIONS



Programmable incremental optical encoder from 1 to 65.536 pulses per rotation



Programmable via USB, without an additional programming box



Programmable without powering up the encoder



Multi-voltage 5...30 VDC Automatic power voltage recognition



0° to 360° reference signal position



Optical Encoder



Incremental Encoder



Programmable Encoder



High shaft load capacity



Vibration and shock resistant



IP65



Express Delivery

- External diameter 58 mm
- Hollow shaft \varnothing 10, 12, 14 or 15 mm
- Protection class IP65 according to DIN EN 60529
- Connection by cable (other cable length available) or industrial connector M12 or M23

Detail A

Micro USB

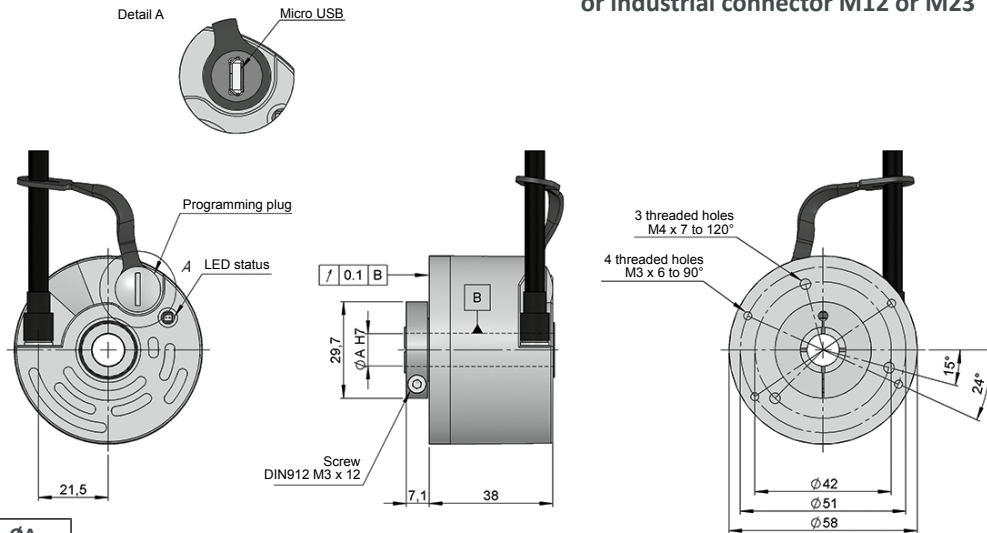

HOLLOW SHAFT	$\varnothing A$
1	10 mm
2	12 mm
3	14 mm
4	15 mm

Drawing hollow shaft type 1, mechanical option type 2, connection type 1

REFERENCE

Reference example: PR90H-21C1C-C

Serie	Mechanical option	Hollow shaft	Output signals	Connection	Power Supply / Electronic output	Pulses number	Special customer
PR90H -	<input type="checkbox"/>	<input type="checkbox"/>	<input type="checkbox"/>	<input type="checkbox"/>	<input type="checkbox"/>	<input type="checkbox"/>	<input type="checkbox"/>
	2. Frontal clamp	1. \varnothing 10 mm 2. \varnothing 12 mm 3. \varnothing 14 mm 4. \varnothing 15 mm	C. A \tilde{A} +B \tilde{B} +O \tilde{O} CONFIGURABLE • CW / CCW • Z 90° and 180° • Z position of 0...360°	1. Helicoidal cable 2. Radial M12 8p CCW 3. Radial M23 12p CCW	C. 5...30 VDC / HTL - TTL CONFIGURABLE • Electronic output HTL / TTL	C. 1...65536 CONFIGURABLE	

Order your reference
Step file 3D

info@hohner-elektrotechnik.de

service available in 24 h

Female connector and the required anti-rotation system are not included in the reference. All options available in the sections "CONNECTION DIMENSIONS" and "ANTI-ROTATION SYSTEMS DIMENSIONS", upon request.

SERIE PR90H

PROGRAMMABLE INCREMENTAL HOLLOW SHAFT ENCODER FOR INDUSTRIAL APPLICATIONS

MECHANICAL SPECIFICATIONS

Materials	Cover: Aluminium Housing: Aluminium Shaft: Stainless Steel
Bearings	Ballraces
Bearings lifetime	1x10 ¹⁰ rev.
Housing fixing	Flexible anti-rotation system (different models available)
Permitted misalignment (Flexible flange)	±0.05 mm axial, ±0.1 mm radial
Shaft fixing	Front clamp
Hollow shaft diameter	10, 12, 14 or 15 mm
Maximum number of revolutions permitted mechanically	6000 rpm
Protection against dust and splashes according to DIN EN 60529	IP65
Rotor inertia moment	60 gcm ²
Starting torque at 20°C (68°F)	≤ 0,02 Nm
Maximum load permitted on axial shaft	40 N
Maximum load permitted on radial shaft	80 N
Weight aprox.	0,5 Kg
Operating temperature range	-20°C to +80°C
Vibration according to DIN EN 60068-2-6	100 m/s ² (10Hz...2000Hz)
Shock according to DIN EN 60068-2-27	1000 m/s ² (6ms)
Maximum pulses per turn	65.536
Connection	2 meters cable or industrial connector M12 or M23 (other cable lengths available on order) Female connector not included

OUTPUT SIGNALS

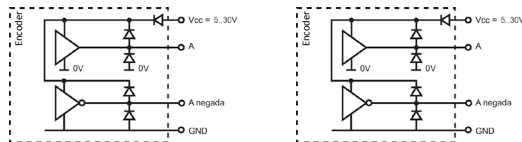

OUTPUT CIRCUIT	TTL	HTL
Reference code	C	C
Power supply	5...30 VDC	5...30 VDC
Consumption*	Typical: 45 mA Max: 150 mA	Typical: 45 mA Max: 150 mA
Max. load capability / channel	±20 mA	±20 mA
Length of cable allowed	1200 m	1200 m
“Low” signal level	VOL < 0.5 VDC	VOL < 2.5 VDC
“High” signal level	VOH > 2.5 VDC	VOH > VCC – 1.5 VDC
Frequency	900 kHz	900 kHz
Short circuit protection	Yes	Yes
Protection polarity inversion	Yes	Yes

Configurable CW - Channel A leads (90° electric) channel B, view from the shaft, shaft rotating clockwise
Configurable CCW - Channel B leads (90° electric) channel A, view from the shaft, shaft rotating clockwise

(*) Peak current of 400mA (1ms) at start-up of the encoder.

SERIE PR90H

PROGRAMMABLE INCREMENTAL HOLLOW SHAFT ENCODER FOR INDUSTRIAL APPLICATIONS

CONNECTION



	Cable 4x2x0,14 95.0008011	Connector M12 8p CCW	Connector M23 12p CCW
GND	Black	7	10
VCC	Red	8	12
A	Yellow	2	5
B	Green	4	8
\tilde{A}	Brown	1	6
\tilde{B}	Blue	3	1
0 (reference)	Grey	6	3
$\tilde{0}$	Orange	5	4

Shield connected to the housing

CONNECTION PC



Cable
uUSB/USB
90.9452

(*) The connection cable uUSB / USB is not included in the reference.

PROGRAMMING DETAILS

LED status:

● *green intermittent indicator:*
Communication between devices

● *red indicator:*
Error detection (overload, low power, optical failure, communications failure, humidity...)
See type of error in the programming software

Configuration options:

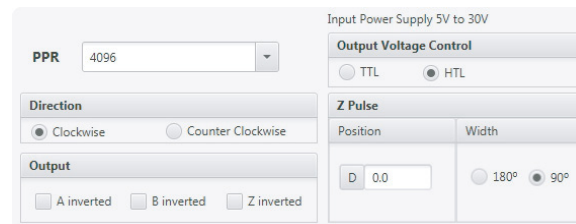

Factory configuration:

- Pulses: 4096 ppr
- Output: HTL
- Direction: Clockwise (CW)
- Position (Z pulse): 0°
- Width (Index, Z, 0): 90°

Download the software and programming manual from: www.hohner-elektrotechnik.de

CONNECTION DIMENSIONS

Female connector not included

Connection 2
Radial
M12 8p
male panel
counter clockwise

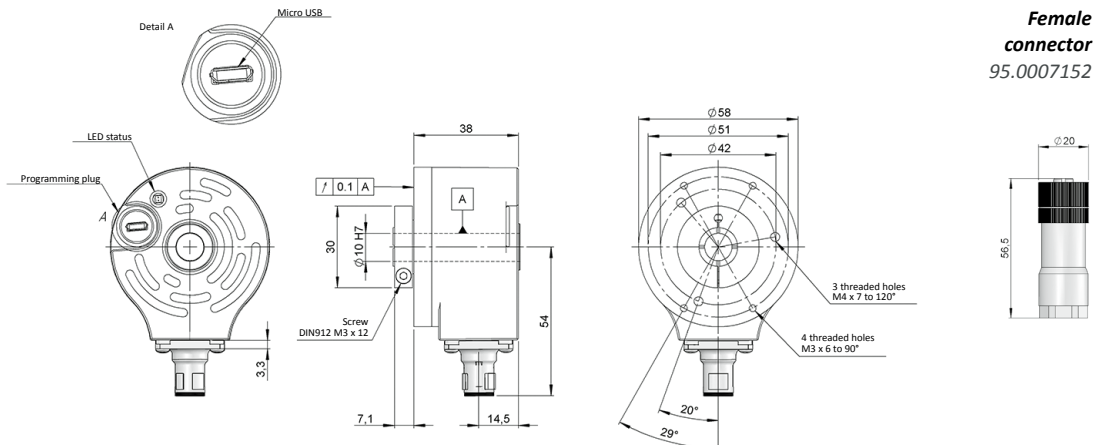

Female connector
95.0007152

SERIE PR90H

PROGRAMMABLE INCREMENTAL HOLLOW SHAFT ENCODER FOR INDUSTRIAL APPLICATIONS

Connection 3

Radial
M23 12p
male panel
counter clockwise

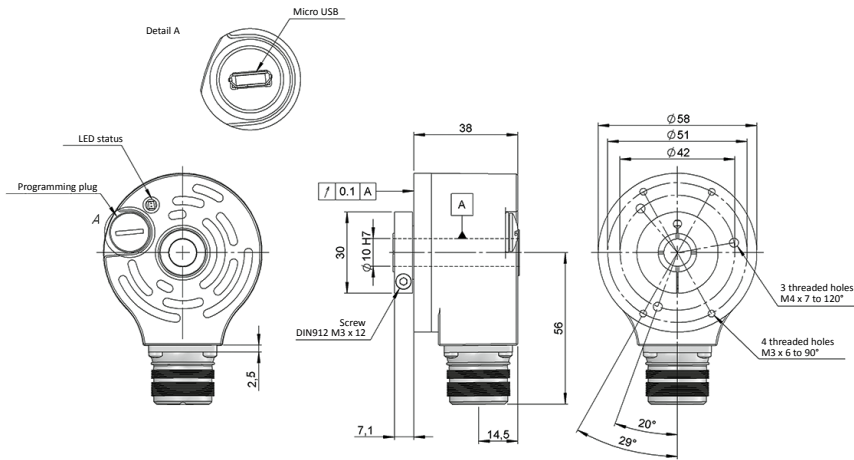

Female connector 95.0007137

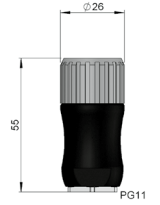

ANTI-ROTATION SYSTEMS DIMENSIONS

Flexible flange

90.1014

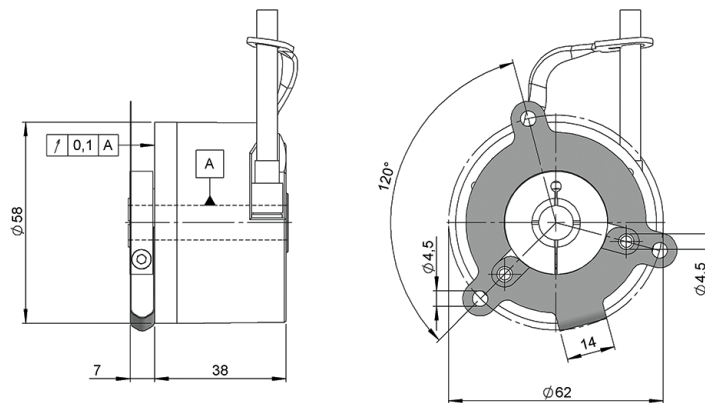

90.1014



Flexible flange

90.1018

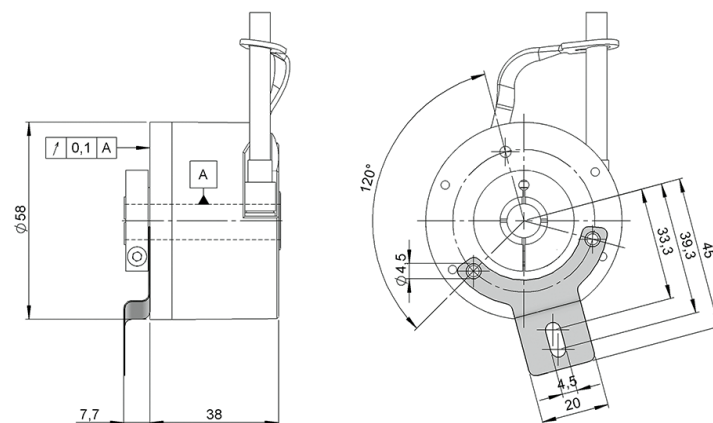

90.1018



SERIE PR90H

PROGRAMMABLE INCREMENTAL HOLLOW SHAFT ENCODER FOR INDUSTRIAL APPLICATIONS

Flexible flange
90.1020

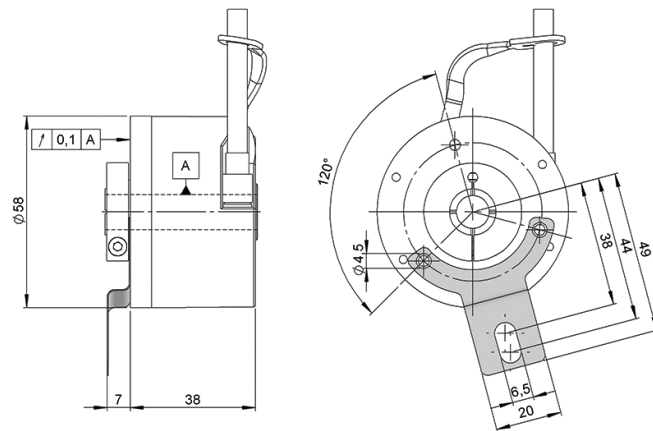

90.1020



Flexible flange
90.1024

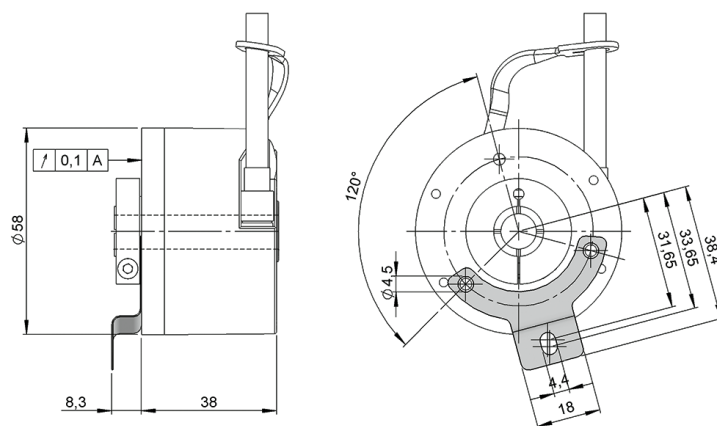

90.1024



Flexible flange
90.1027

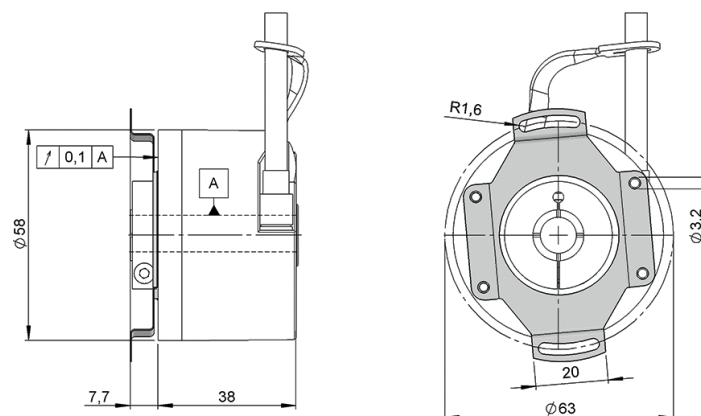

90.1027

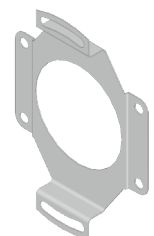

SERIE PR90H

PROGRAMMABLE INCREMENTAL HOLLOW SHAFT ENCODER FOR INDUSTRIAL APPLICATIONS

Flexible flange
90.1075

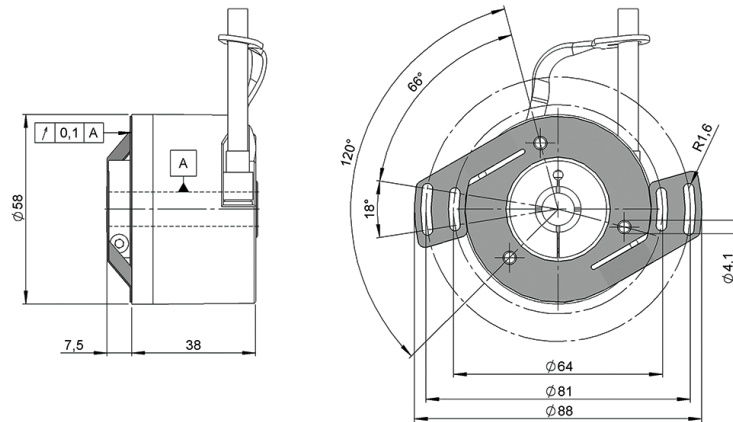

90.1075



PRE-ASSEMBLED CABLES

89.003.02.047.xx

length

Cable 3x2x0,14+2x0,34

Female connector

M12 8p CW



89.010.02.015.xx

length

Cable 3x2x0,14+2x0,34

Female connector

M23 12p CW

